

# Merlin GM150 / GM151



## INSTALLATION GUIDE

Please read these instructions carefully before use and retain for future reference.

These instructions can also be downloaded in electronic form on the product website.

For specific requirements that may deviate from these instructions – contact your supplier.

Scan to view Operations Manual:



**americangassafety.com**



## Contents

Installation .....	2
General Safety Cautions .....	2
EMI and RF Interference Considerations .....	3
Coverage .....	3
Positioning .....	3
Mounting Instructions .....	5
Circuit Board Overview .....	6
Main PCB .....	7
Power & Digital RS485 Wiring .....	8
Analog Output Wiring .....	9
Power & Relay PCB .....	10

# Installation

## General Safety Cautions

 Failure to observe the following may cause injury to persons and/or property.

Installation must be carried out by a licensed and insured contractor and installed in areas at risk of gas leaks and higher concentrated areas e.g., near boilers, valves, or areas of critical protection, located in positions determined by those who have knowledge of gas dispersion, the process plant system and equipment involved, and in consultation with both safety and electrical engineering personnel.

Final positioning of gas detectors should be indicated by the characteristics of the gas being detected and other environmental factors. Seek advice where necessary. Take into account the design of the air flow patterns within the area, sensors should be installed in the correct orientation as per the manufacturer's specification, and ease of access should be accounted for to allow for any forms of maintenance throughout its operational life.

Installation must be in accordance with the recognized standards of the appropriate authority in the country concerned. For Europe, see EN 60079-29-2, EN 62990-2 and/or EN44554-4. For installations in North America, the National Electrical Code (NFPA 70) should be strictly observed. All appropriate local and national regulations should be observed.

## EMI and RF Interference Considerations

---

All electronic devices are susceptible to EMI (Electromagnetic Interference) and RFI (Radio Frequency Interference). Our products are designed to reduce the effects of these interferences. However, there are still circumstances and levels of interference that may cause the equipment to respond to these interferences. Reduce the possibility by:

- Avoiding installation locations near high foot traffic and high energy equipment.
- Confirming equipment is properly grounded if required and shielded cabling.

## Coverage

---

50ft radius per detector is a reasonable guide, therefore multiple detectors may be required to adequately protect property and persons. However, coverage should be determined by those who have knowledge of gas dispersion, target gas characteristics, the environment, process plant system(s) and intended functions etc., and in consultation with both safety and electrical engineering personnel.

## Positioning

---

There are no specific standards governing gas detector locations (unlike fire detection systems); there are, however, general guidance documents. The most relevant being *IEC 60079-29-2*. Much of what it covers is also relevant to toxic gas & oxygen monitoring equipment. Recommended heights may vary based on air flow and other environmental conditions in addition to the proposed application, location, and target gas.

The composition of the target gas and its density relative to air are used as the basis for the recommended height of sensors.

Generally, the installation height of a sensor for a heavy gas (e.g., LPG) would be close to the lowest point in the area, and for a light gas (such as methane or hydrogen) would be close to the highest point in the area.

These typical heights may vary based on application.

Target Gas	Typical Install Height
Carbon Monoxide (CO)	Breathing Zone – 4 - 6ft from ground level.
Nitrogen Dioxide (NO <sub>2</sub> )	Breathing Zone or, Low Level - 1ft from ground level.
Carbon Dioxide (CO <sub>2</sub> )	Breathing Zone - 1700mm (5ft 6”) from ground level
Natural Gas (NG) / Methane (CH <sub>4</sub> )	High Level - 300mm (1ft) from ceiling
Propane / Butane (LPG)	Low Level - 300mm (1ft) from ground level
Hydrogen (H <sub>2</sub> )	High Level - 300mm (1ft) from ceiling
Oxygen (O <sub>2</sub> )	Breathing Zone – 4 - 6ft from ground level.

Observe the following also.

- Ease of access to the equipment for functional testing and servicing.
- How gas may behave due to natural or forced air currents.
- Any regulation/standard/code that locations are bound by.

## Mounting Instructions

- ⚠ Position at a location with minimum noise, vibration, and environmental variation.
- ⚠ Damage when creating entry points or attempting to remove the circuit board may void any warranty.
- ⚠ Avoid environmental conditions outside of this specification that could potentially impede the accuracy and operation of the equipment such as condensation; vibration; temperature, pressure, the presence of other gases, electromagnetic interference, and draft zones.

1. Carefully remove the front cover from the unit by using a Phillips screwdriver.
2. The enclosure base has 8 optional mounting screw positions, as shown below.
3. Fixing straight to wall – drill 0.2" (5mm) holes, insert plugs and use the four screws (No.4 Pozzi) provided.
4. There are 5x pre-fractured knockouts for cable entry on the rear of the base and 2x knockouts on the top and bottom.
5. After executing the mounting/connections secure the front cover screws.



**Mounting holes**



**Conduit Knockouts**

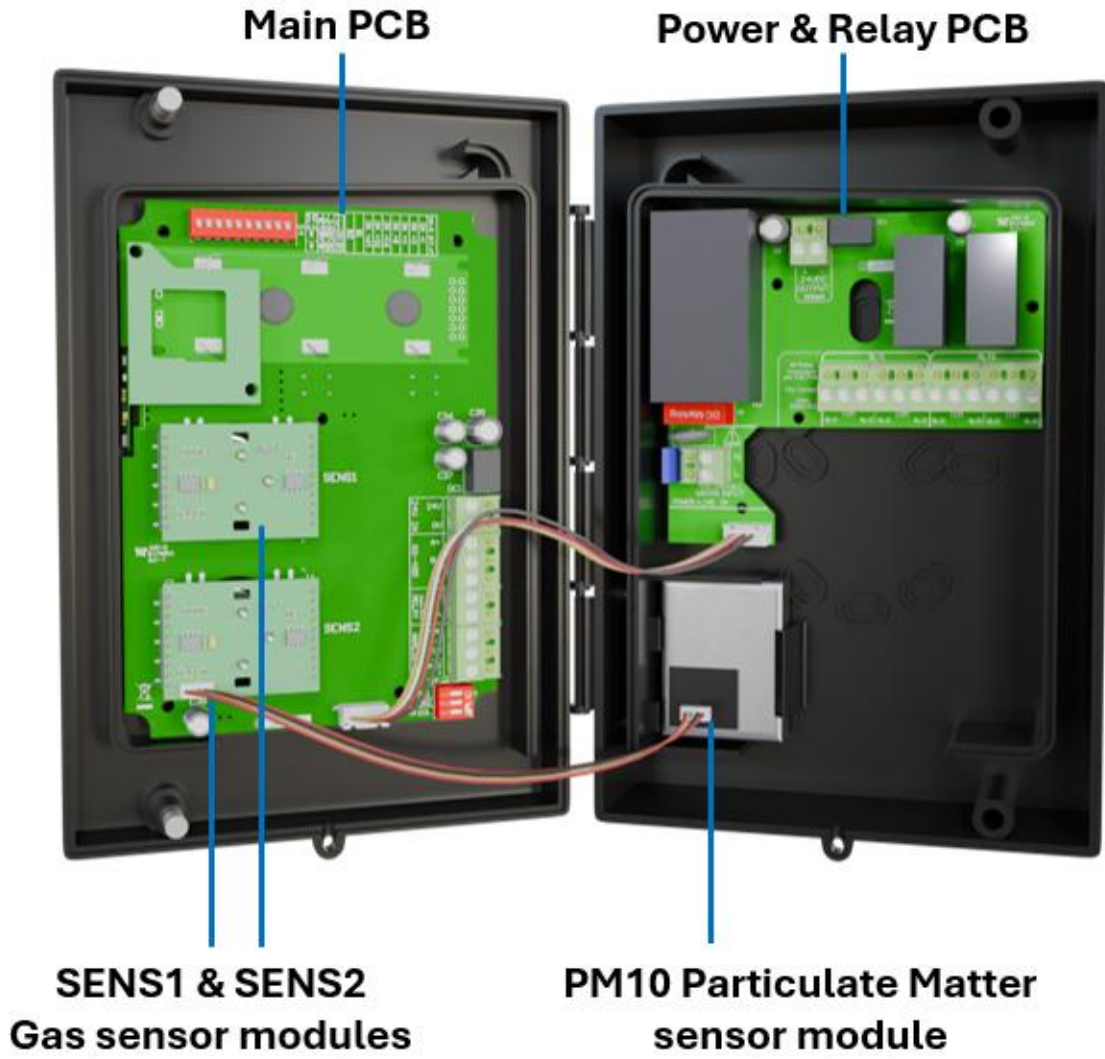

# Main PCB

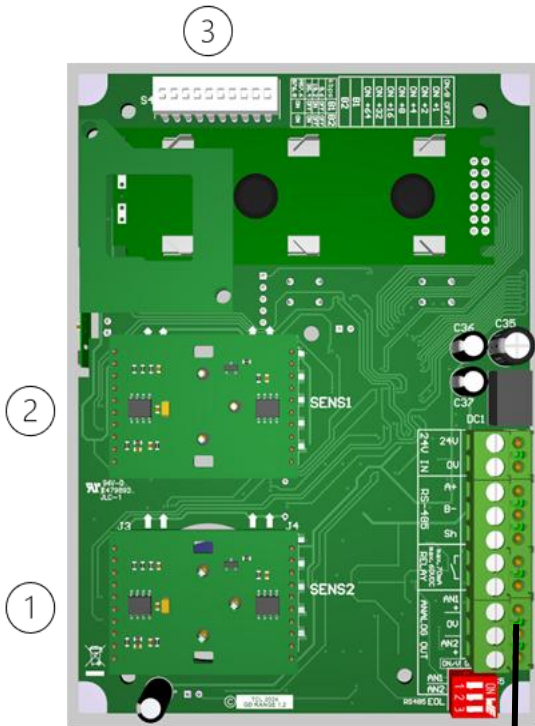

1. S2 Gas Sensor - Replaceable module
2. S1 Gas Sensor - Replaceable module
3. RS485 Configuration dip-switches  
Protocol / Network Address / Baud Rate
4. 3-Way Dip-switch
  - AN1 & AN2 Voltage or Current Output
  - RS485 120ohm Termination Resistor

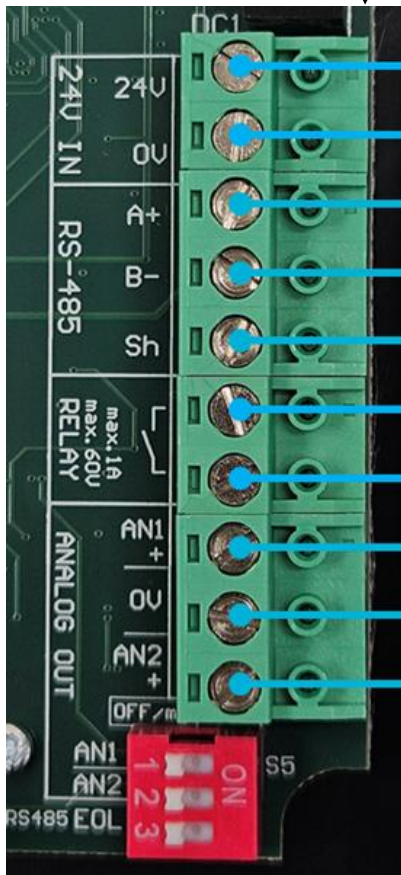
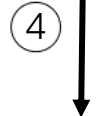

- Power Input 12-32V AC/DC (Nominal 24V)
- RS-485 Digital Output Modbus RTU or BACnet MS/TP
  - +
  - 
  - Sh

**See:** Power & Digital RS485 Wiring for details
- Signal Relay Output 1A, 60V max
- AN1 & AN2 Analog Output (mA or V)
 

**See:** Analog output wiring for details

## Power & Digital RS485 Wiring

- ⚠ Warranty may be void if damage occurs to the circuit board from use of solid core wire attached directly to terminals.
- ⚠ The equipment requires a continual supply of electrical power – it will not work without power.

The equipment is powered by low voltage 12-24V DC or AC.

Cable specifications ultimately determine the distance the sensors can be mounted away from a control panel or power supply. Consider voltage drops due to cable resistance and strip the cables as short as possible ensuring bare wires, e.g., wire shields, do not contact with the circuit board (risk of short-circuit).

For the Modbus RS-485 or BACnet MS/TP network use a 3-core, 2 twisted pair + ground, shielded cable with 120 Ω characteristic impedance. Any cable with similar characteristics can be used to connect all the devices together. Daisy chain wires running to additional monitors – 127 sensors max per cable run. First and last device in bus requires a termination resistor. Use RS485 EOL switch to terminate by turning ON.

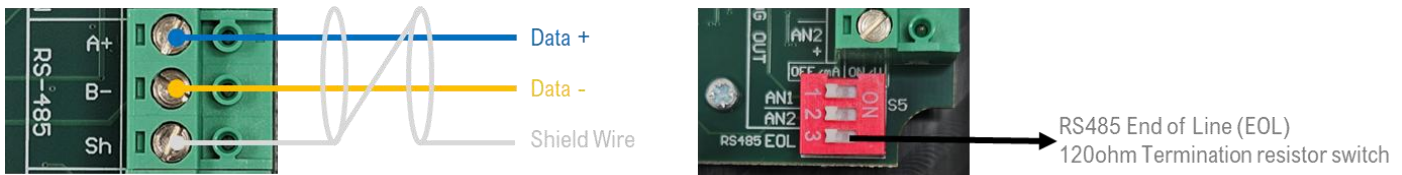

All wiring should be run within properly grounded (earth or safety) conduit. The cable shield should be connected to earth ground at the controller/power supply that is providing power to the equipment.

Low voltage wiring must not be within the same conduit as any line/mains voltage wiring.

To ensure optimal performance of the network ensure the following guidelines are implemented:

- Ensure the equipment is configured in a single bus topology, connecting multiple buses in parallel or branching multiple units from the main bus, may introduce impedance mismatches, reflections and/or signal distortions.
- Ensure equipment at each end of a bus has the 120 Ω terminating resistor switch enabled.
- Ensure A+/B- signal polarity is maintained throughout the network.
- Connect shield wires to earth/ground of the central control panel if no shield connection is present.
- Ensure cable shield integrity is maintained throughout the network.
- Do not use shield connection for signal ground. Use cable that provides dedicated ground conductor for signal ground. Connect signal ground to (0V/GND) terminal.

### RS485 Dipswitch Settings

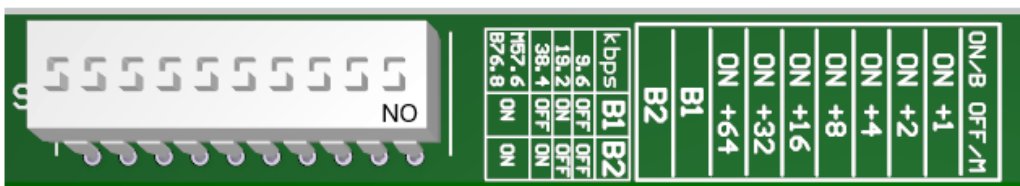

Switch	Function	Label	Parameter
1	RS485 Selection	OFF/M ON/B	Off/M: Modbus RTU / On/B: BACnet MS/TP
2~8	Slave ID	-	Achieved by adding binary switch values together. Example #4 ON + #16 ON = ID: 20. (Max. 127)
9~10	Baud Rate	B1 / B2	On/Off configuration achieves either. 9600, 19200, 38400 or 57600 (Modbus) / 76800 (BACnet)

## Analog Output Wiring

⚠ Outputs are scaled to the high alarm concentration level.

Two linear voltage or current output terminals are available and often used to regulate external fan speed controllers. The AN1 & AN2 dipswitch will change from 4-20mA to 2-10V. The output is scaled to the Alarm H (high) setpoint, and the gas closest to the Alarm H will take priority and drive the speed (default).

Configure dipswitches to select current (OFF) or voltage (ON) for each output (AN1 and AN2).

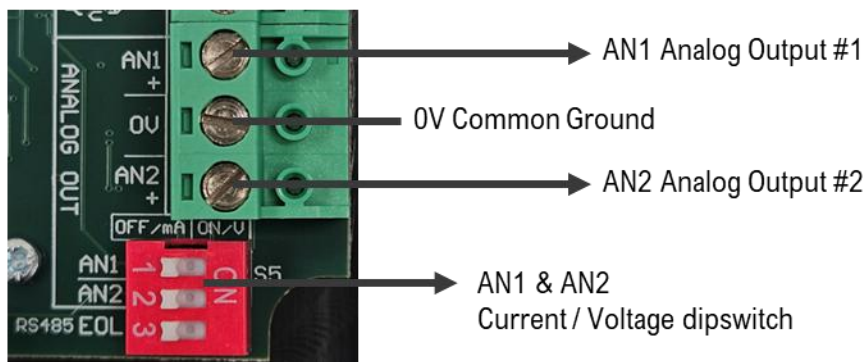

### Gas Concentration to High Alarm Level

(See section: Configuration List)

0-100%

20-100%

0%	0v	0mA	2v	4mA
100%	10v	20mA	10v	20mA

# Power & Relay PCB

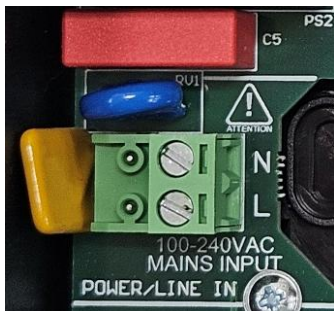
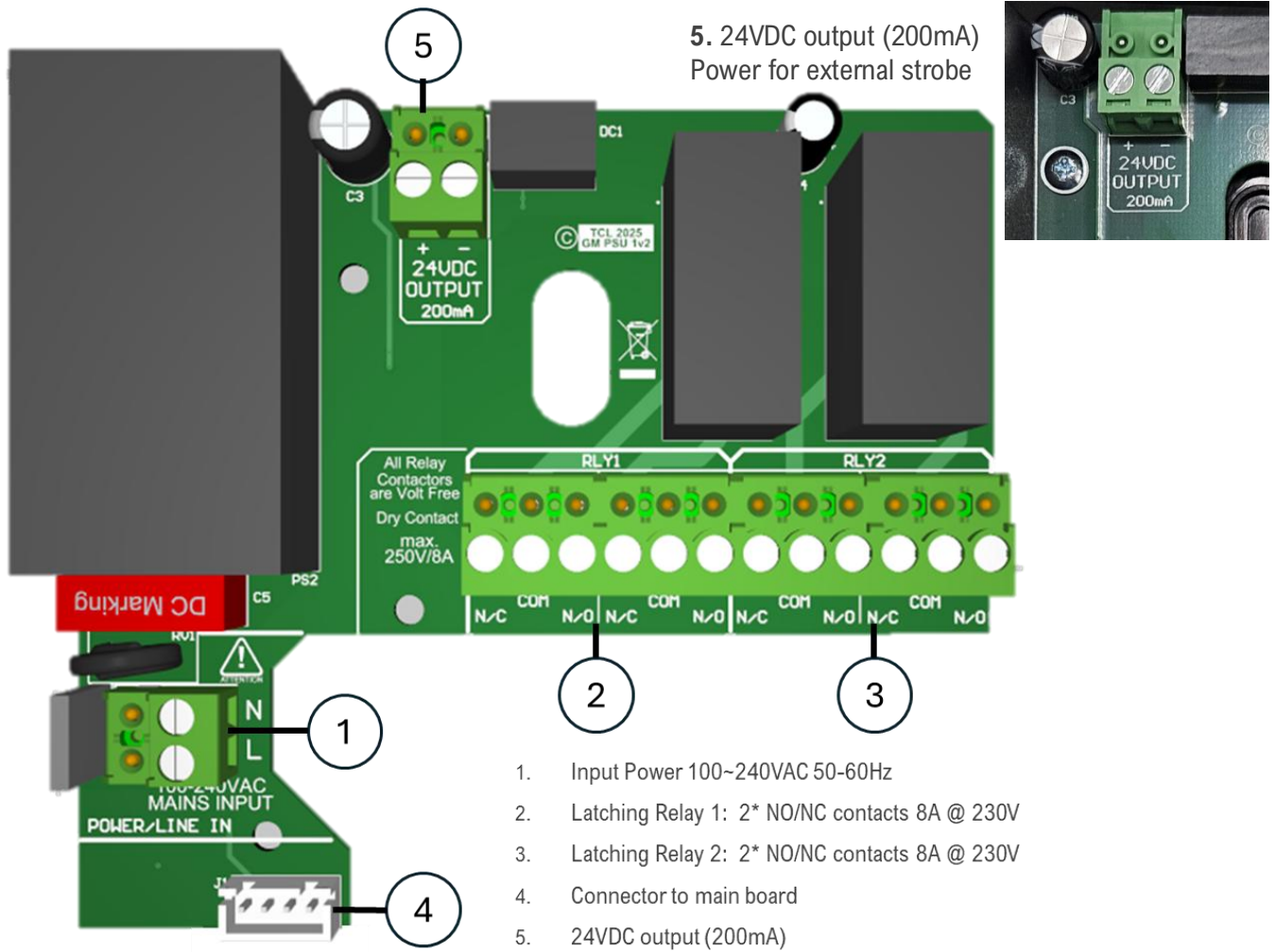

1. Power Input  
100~240VAC 50-60Hz

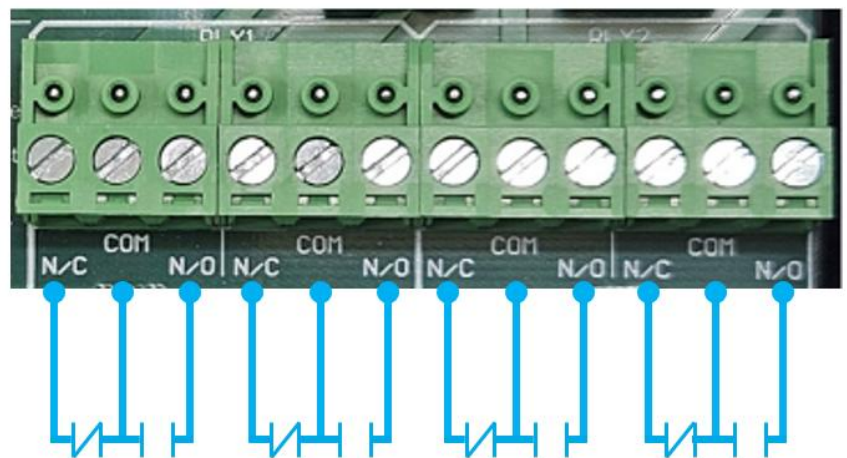

2. RLY 1  
2 \*NO/NC contacts 8A @ 230V

3. RLY 2  
2\* NO/NC contacts 8A @ 230V

**Please pass this manual to the system owner/user.**

Date of Installation:	
Installation Location:	
Organization:	
Stamp/Signature of the installer:	

## American Gas Safety LLC

[www.americangassafety.com](http://www.americangassafety.com)

**Head office:**

6304 Benjamin Road, Suite 502, Tampa, FL 33634

**Tel:** (727) 608-4375

**Email:** [info@americangassafety.com](mailto:info@americangassafety.com)

American Gas Safety LLC is the owner of this document and reserves all rights of modification without prior notice.

