

AGSRTFT NDIR Refrigerant Detector Compatible with MerlinGuard



24VAC or DC Power Input



Standalone Detector or Used with an AGS Controller



Traffic Light Indicator Display Changes Color Dependent On Gas Levels



MODBUS Communications



Modern & Compact Design



Alarm Relay Dry Contact



Plug & Play Installation



In-Built Audible Alarm

Product Overview

The TFT range of AGS detectors work in combination with the AGS Merlin range of Gas Detection panels and Utility Controllers. The AGSRTFT features an NDIR sensor for industrial and commercial indoor applications. Compact, modern, digital design makes the units aesthetically pleasing and easy to install.

Detectable Gases and Part Numbers

GAS	Model#	Pre Alarm (PPM)	High Alarm (PPM)	Mounting Height
R-1233zd	RTFT-PRO-1233ZD	75	1000	1ft A.F.F.
R-1234yf	RTFT-PRO-1234YF	75	1000	1ft A.F.F.
R-1234yf	RTFT-LITE-1234YF	175	1000	1ft A.F.F.
R-1234ze	RTFT-PRO-1234ZE	75	1000	1ft A.F.F.
R-1234ze	RTFT-LITE-1234ZE	175	1000	1ft A.F.F.
R-123	RTFT-PRO-123		50	1ft A.F.F.
R-125	RTFT-PRO-125	75	1000	1ft A.F.F.
R-134a	RTFT-PRO-134A	75	1000	1ft A.F.F.
R-134a	RTFT-LITE-134A	175	1000	1ft A.F.F.
R-143a	RTFT-PRO-143A	75	1000	1ft A.F.F.
R-227ea	RTFT-PRO-227EA	75	1000	1ft A.F.F.
R-22	RTFT-PRO-22	75	1000	1ft A.F.F.
R-32	RTFT-PRO-32	75	1000	1ft A.F.F.
R-32	RTFT-LITE-32	350	1000	1ft A.F.F.
R-404a	RTFT-PRO-404A	75	1000	1ft A.F.F.
R-404a	RTFT-LITE-404A	175	1000	1ft A.F.F.
R-407a	RTFT-PRO-407A	75	1000	1ft A.F.F.
R-407c	RTFT-PRO-407C	75	1000	1ft A.F.F.
R-407c	RTFT-LITE-407C	175	1000	1ft A.F.F.
R-407f	RTFT-PRO-407F	75	1000	1ft A.F.F.
R-410a	RTFT-PRO-410A	75	1000	1ft A.F.F.
R-410a	RTFT-LITE-410A	350	1000	1ft A.F.F.
R-417a	RTFT-PRO-417A	75	1000	1ft A.F.F.

GAS	Model#	Pre Alarm (PPM)	High Alarm (PPM)	Mounting Height
R-422a	RTFT-PRO-422A	75	1000	1ft A.F.F.
R-422d	RTFT-PRO-422D	75	1000	1ft A.F.F.
R-424a	RTFT-PRO-424A	75	990	1ft A.F.F.
R-427a	RTFT-PRO-427A	75	1000	1ft A.F.F.
R-434a	RTFT-PRO-434A	75	1000	1ft A.F.F.
R-438a	RTFT-PRO-438A	75	990	1ft A.F.F.
R-442a	RTFT-PRO-442A	75	1000	1ft A.F.F.
R-448a	RTFT-PRO-448A	75	860	1ft A.F.F.
R-449a	RTFT-PRO-449A	75	800	1ft A.F.F.
R-449a	RTFT-LITE-449A	175	800	1ft A.F.F.
R-450a	RTFT-PRO-450A	75	880	1ft A.F.F.
R-452a	RTFT-PRO-452A	75	790	1ft A.F.F.
R-452b	RTFT-PRO-452B	75	870	1ft A.F.F.
R-453a	RTFT-PRO-453B	75	1000	1ft A.F.F.
R-454a	RTFT-PRO-454A	75	690	1ft A.F.F.
R-454b	RTFT-PRO-454B	75	850	1ft A.F.F.
R-454c	RTFT-PRO-454C	75	620	1ft A.F.F.
R-455a	RTFT-PRO-455A	75	650	1ft A.F.F.
R-507	RTFT-PRO-507	75	1000	1ft A.F.F.
R-513a	RTFT-PRO-513A	75	650	1ft A.F.F.
R-515a	RTFT-PRO-515A	75	810	1ft A.F.F.
R-515b	RTFT-PRO-515B	75	810	1ft A.F.F.

AGSRTFT Technical Specifications

General	
Model:	AGSRTFT-***
Target Gases:	See table above
Size: (H x W x D)	5.95 x 4.37 x 1.97" (151 x 111 x 50mm)
Housing Material:	ABS Polyac - PA765
Mounting:	1FT A.F.F. - Indoor Use - Wall Mounted
Weight:	Max. 1.77oz (0.05kg)
User Interface	
Display:	1.8" TFT Color Digital Display
Screen Brightness:	Non-Adjustable
Visual Indicators:	TFT visual. Green: Normal; Yellow: Pre-Alarm; Red: Alarm
Audible Alarm:	>95dB @ 3.28ft (1m)
Buttons:	None
Language:	English
Power Supply	
Power Consumption:	90mA Max @ 24vdc
DC Power:	12-32 VDC - Nominal 24 VDC
Internal Fuse:	None
Equipment	
Overvoltage Category:	III
Pollution Degree:	3
I/O	
Relay:	Volt Free (Normally Closed / Common / Normally Open) 1x 30vdc 2A (Non-Latching)
Environmental	
Operating:	-10 ~ 50°C / 14 ~ 122°F 30 ~ 80% RH (non-condensing)
Storage:	-25 ~ 50°C / -13~122F° up to 95% RH (non-condensing)
Atmospheric Pressure:	70-110kPa
Altitude Rating:	<9500ft
Wiring	
Typical	#18-24AWG Power Pair; #18-24AWG Data Pair-Tinned copper.
Approvals	
Electromagnetic Compatibility and Electrical Safety	BS/IEC/EN 61010-1 EMC EN 50270
Other	
Communication	RS485 MODBUS RTU

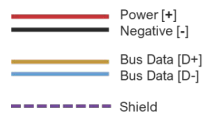
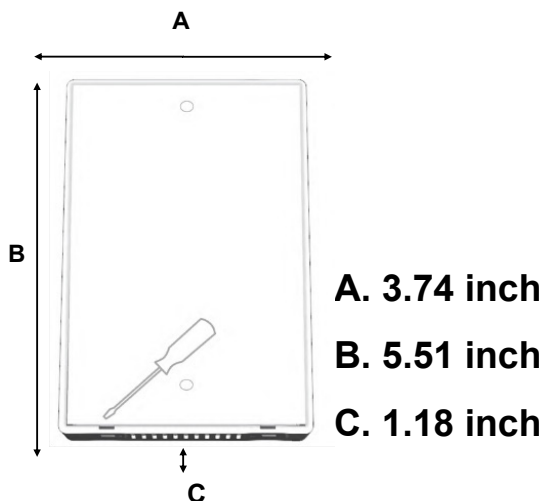

Multiple detectors daisy chained in series

24Vdc Power Input/Output & Data
Compatible with the Merlin GDP-X range.

