

AGS-GSV

Gas Solenoid Valve

Installation and Maintenance Instructions



ISO 9001 Class A AS-4629-2005



American Gas Safety
6304 Benjamin Road
Suite 502
Tampa
FL 33634

Phone: (727)-608-4375

Email: info@americangassafety.com

In this procedure document we have endeavored to make the information as accurate as possible. We cannot accept any responsibility should it be found that in any respect the information is inaccurate or incomplete or becomes so as a result of further developments or otherwise.

INTRODUCTION

The AGS-GSV solenoid valves are widely used in gas distribution to provide isolation and emergency shut-off.

The valves can be used on various hydrocarbon gases including natural gas, methane, and liquid petroleum gas.

OPERATION

The AGS-GSV solenoid valves will normally be in the closed position, but when energized will open quickly and a blue indicator light will be lit on the terminal box attached to the coil.

There are ¼"-18 NPT threaded holes on both sides of the valve body and at the bottom. These can be used for various applications but notably a CPI (closed position indicator) or gas proving system.

TECHNICAL SPECIFICATION

Opening time:		< 1 second
Closing time:		< 1 second
Max. operating frequency:		20 times per minute
Maximum working pressure:	¾" to 2"	5Psi (145 in w.c.)
Protection level:		IP54
Ambient / fluid temperature:		5 to 140° F
Coil temperature:		149° F
Body connections - threaded:		NPT
Seal material:		NBR rubber
Body material:		Aluminum
Spring material:		AISI 302 stainless steel

ELECTRICAL SPECIFICATION

Voltage:	110/120 V ac
Rating:	50/60 Hz
Coil Level F:	360° rotation
Suitable for:	Permanent excitation

STANDARDS

Listed to:	UL Listed File No. MH64653 AS-4629-2005 CE
Complies with:	CSA/ANSI Z21.21 - CGA 6.5 ISO 9001 Class A

DIMENSIONS

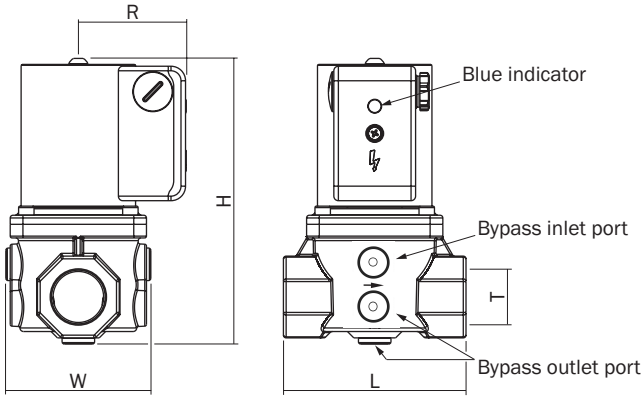

Code	T	L	W	H	R	
AGS-GSV34	¾ - 14 NPT	3.62"	3.00"	6.14"	2.32"	
AGS-GSV1	1 - 11.5 NPT	3.94"	3.15"	6.22"	2.32"	
AGS-GSV114	1¼ - 11.5 NPT	5.87"	4.53"	8.50"	2.80"	
AGS-GSV112	1½ - 11.5 NPT	5.87"	4.53"	8.50"	2.80"	
AGS-GSV2	2 - 11.5 NPT	6.69"	5.59"	9.06"	3.00"	

CAPACITY

The capacity in ft³/hr at ΔP = 1 in w.c.

Code	Size	ft ³ /hr
AGS-GSV34	¾"	523
AGS-GSV1	1"	590
AGS-GSV114	1¼"	1,360
AGS-GSV112	1½"	1,663
AGS-GSV2	2"	2,355

GENERAL INSTALLATION RECOMMENDATIONS

- The AGS-GSV gas solenoid valve should be mounted directly in a vertical pipeline or in a horizontal pipeline with the coil uppermost.
- Check that the site conditions comply with the technical specification of the valve.
- The flow direction arrow on the valve body must match the direction of flow.
- Thoroughly purge the pipeline before installing the valve to prevent debris entering the valve and damaging the diaphragm and causing premature failure.
- A gas filter should be installed upstream of the valve to prevent the ingress of debris and prolong the interval between services and the life of the valve.
- **IMPORTANT:** the valve is not explosion proof.
- If installed outdoors or in a harsh environment the valve should be protected accordingly.
- If recommended install a bypass around the gas solenoid valve to aid isolation and future maintenance
- If the valve fails to open or close check that the power supply is connected correctly and turned on. Also check the pressure within the system is within the technical specification of the valve.
- If not installed on the valve, the coil should be stored indoors between 32 to 104° F with a relative humidity of 80% or less. It should not be stored in the open air.

PIPE CONNECTION

- The flow direction arrow on the valve body must match the direction of flow
- The inlet (up stream) and outlet (downstream) pipes must be in-line and coaxial.
- Pipes should be adequately supplied with pipe supports adjacent to the valve.
- When making the joints PTFE tape or a pipe sealing compound should be used to make a gas tight joint.

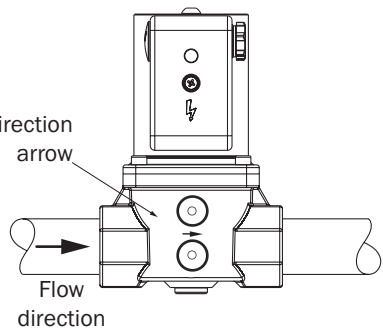

PIPE CONNECTION CONTINUED

- Use a suitably sized spanner or wrench on the flats of the octagonal or hexagonal ends of the valve body when tightening the pipe into the body.
- Do not use any other part of the valve or solenoid to tighten the pipe into the body.

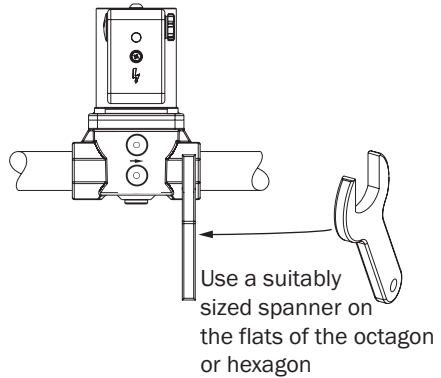

- After making the pipe joints check that they are gas tight.
- Brush a soap solution or use a leakage detection spray around each joint.
- Test the joints with dry air at 2 times the maximum working pressure - see Technical Specification on page 1.
- All joints must be tested individually.
- If bubbles are present it indicates that there is leakage from the joint.
- If there is a leak the joint must re-made and the leakage test repeated.
- The system cannot be used until all joints are proven to be leak tight.

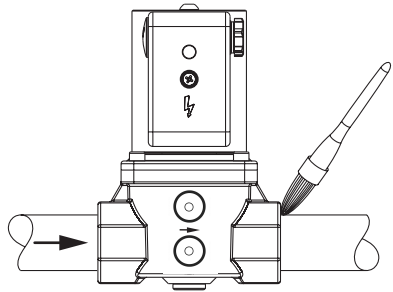

EXISTING INSTALLATION

If installing the gas solenoid valve into an existing system;

- Turn off gas supply before starting installation.
- Disconnect power supply to prevent electrical shock and/or equipment damage.
- Take care to ensure that dirt cannot enter the gas valve during handling and installation.

ELECTRICAL INSTALLATION

- Turn off power supply before making electrical connections or servicing any part of the system.
- Provide a fused isolation switch for the power supply to the actuator.
- Ensure that wiring is in accordance with local regulations.
- Use wire which can withstand 220°F ambient.
- Follow the instructions supplied by the appliance manufacturer.
- Please confirm the power specification corresponding to the solenoid valve before installation. The power supply should strictly correspond to the rated power supply of the solenoid valve.
- Remove the white protective cap on one side of the junction box and replace it with the corresponding cable connector.
- The AC power supply should be correctly connected to live (L), neutral (N) and earth terminals.
- After the power connection is completed, the electric box cover plate should be replaced ensuring that the sealing gasket is correctly seated before tightening the fixing screw.

Electric box
cover plate

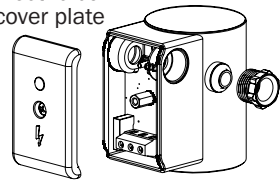

Incorrect installation or improper use may cause electrical damage or personal injury.

ADDITIONAL BODY PORTS

The solenoid valve body is provided with additional body ports for other possible applications.

- Users can add detection, input, output, and other auxiliary devices using the bypass connections
 - The bottom connection can be used to install sensors (such as CPI sensor, which can be used to monitor whether the valve is open or closed).
 - To ensure the sealing reliability, please do not disassemble any of the bypass connections if no additional equipment is needed.
 - **ATTENTION:** if additional equipment is needed or the plug is disassembled, the sealing of the connection should be strictly checked.
- Ensure safety before moving on to the next installation test.

COIL CARE

The coil can only be powered when attached to the valve. The power must be disconnected if the coil is removed from the valve, failure to do this will result in the coil burning out.

Never energise the coil if not fitted to the valve otherwise this will shorten its life and eventually result in failure.

The coil should be securely fitted to valve, loose fitting will shorten the life of the coil.

Surge/spikes should be prevented from reaching the coil as this will result in failure.

The power supply must be within the tolerance indicated otherwise failure of the capacitor will occur.

The continuous service (100%ED) causes inevitable coil heating.

Depending on working environment the coil surface will be very hot. This situation is absolutely normal.