

# AGSENCFM Datasheet

## Flush Mount Solenoid Valve Enclosures



### Product Overview

Designed for general purpose indoor commercial use to enclose mechanical valves such as solenoid valves & ball valves. The hinged cover with latch provides easy access during installation and maintenance.

### Standards



IEC 60529, IP20

### Construction

- ✓ Three piece assembly consisting of a base, wrapped and door.
- ✓ Components are attached and secured with metal screws.
- ✓ 14 gauge reverse formed base provides clearance for mounting hardware.
- ✓ Punched for left or right hinging of the door and ease of assembly.
- ✓ Wrapper is formed from 16 gauge steel, with no knock-outs in the sides.
- ✓ Flush mounting door assembly formed from 16 gauge steel.
- ✓ Door is fastened with a slotted quarter turn latch,
- ✓ A bonding stud is provided on the door and a grounding screw is provided in the enclosure.

### Finish

- ✓ Base, wrapped and door are finished in ANSI 61 gray powder coating

### Installation

**Step 1:** Base, wrapped and door are finished in ANSI 61 gray powder coating

**Step 2:** Drill four (or six) .312inch diameter holes in mounting surface. Use

enclosure as the template to determine number of holes required and drilling locations.

**Step 3:** Fasten flush mount enclosure to mounting surface using M6 screws, flat washers, and hex nuts as shown.

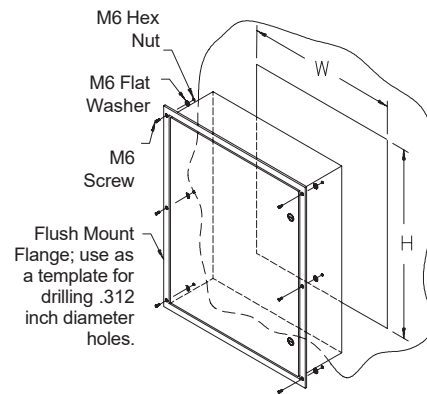

### Sizes Available

Part Code	Height ± .25 (inches)	Width ± .25 (inches)	Depth ± .25 (inches)
AGSENC12126FM	12	12	6
AGSENC16126FM	16	12	6
AGSENC20166FM	20	16	6
AGSENC20206FM	20	20	6
AGSENC24208FM	24	20	8
AGSENC24248FM	24	24	8
AGSENC30248FM	30	24	8

Find out more

**American Gas Safety LLC**

[www.americangassafety.com](http://www.americangassafety.com)

Head office:

6304 Benjamin Road, Suite 502, Tampa, FL 33634

Tel: (727) 608-4375

Email: [info@americangassafety.com](mailto:info@americangassafety.com)

