

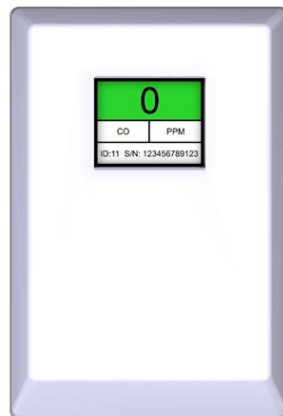

Gas Detector TFT Gas Detector TFT-FL

Addressable Safe Area Fixed Gas Detector



Installation, Operation & Maintenance

Please read this manual carefully and retain for future use.

AGS supply a range of remote gas detectors including carbon monoxide (CO), natural gas/methane (NG), liquid petroleum gas (LPG), Carbon Dioxide (CO₂) and also oxygen (O₂) that are compatible with our range of Merlin control panels connecting up to 16 detectors (control panel dependant) per cable run to monitor gas levels in safe areas.

- The information contained within this manual should be referenced for typical installation and operation only.*
- For specific requirements that may deviate from the information in this manual – contact your supplier.*

Contents

Important Warning Statements	3
Installation	4
Typical Location & Positioning.....	4
Access & Mounting.....	5
Internal Board Overview.....	5
Wiring a Detector (GDP2X or GDPX+ Control Panel).....	6
Creating a Detector Chain.....	6
Detector ID Switches.....	7
120ohm Termination Resistance.....	7
Wiring a Detector (GDP2 or GDP4 Control Panel).....	8
Wiring your Detector (Merlin 'S' Control Panels).....	8
Audible Alarm Switch.....	8
Factory Set Condition.....	8
Installation Tips.....	9
Operation	9
Initial Power-Up (Commissioning).....	9
Digital Indication.....	10
Alarm Set Points.....	10
General Maintenance	11
Cleaning.....	11
Manual Circuit Simulation Test.....	11
Service Reminders.....	11
Bump Test (Gas Response Check).....	11
Standard Test Gases.....	12
Bump Test Procedure.....	12
Reset Service Message.....	13
End of Operational Life (EOL).....	13
Technical Specification.....	15



Important Warning Statements

Please take the time to thoroughly read these instructions which should be retained for future reference.

Detectors are shipped pre-calibrated and configured.

The expected lifetime of a gas sensor is 3-10 years upon initial power up dependant on your target gas and environmental factors. The device will display a message to indicate this time and should immediately be replaced.

It is recommended that this device be commissioned upon installation and serviced annually by a competent person.

Do not apply lighter gas or other aerosols to the device – this will cause extreme damage to the sensors.

High concentrations of alcohol found in many products may damage, deteriorate or affect the gas sensing elements.

This device is designed to detect the gas type displayed on the screen only.

It is not designed to detect smoke, fire or other gases and should not be used as such.

This device provides early warning of the presence of gas, usually before a healthy adult would experience symptoms. This warning is possible provided your alarm is installed and maintained in accordance with this manual.

Never ignore your device when in alarm.

This device requires a continual supply of electrical power – it will not work without power.

This device should not be used to substitute proper installation, use and/or maintenance of fuel burning appliances including appropriate ventilation and exhaust systems.

Multiple detectors may be required to adequately protect property and persons.

This device does not prevent dangerous gasses from occurring or accumulating.

Actuation of your alarm indicates the presence of dangerous levels of gas.

The device is not intended for use in potentially explosive atmospheres.

Seek fresh air supply and contact your local gas emergency service should you suspect a gas leak.

This unit may not fully safeguard individuals with specific medical conditions. If in doubt, consult a doctor/physician.

Your product should reach you in perfect condition, if you suspect it is damaged, contact your supplier.

Manufacturer's Warranty

Warranty coverage: The manufacturer warrants to the original consumer purchaser, that this product will be free of defects in material and workmanship for a period of three (3) years from date of purchase or one (1) years for oxygen detectors.

The manufacturer's liability hereunder is limited to replacement of the product with repaired product at the discretion of the manufacturer. This warranty is void if the product has been damaged by accident, unreasonable use, neglect, tampering or other causes not arising from defects in material or workmanship. This warranty extends to the original consumer purchaser of the product only. **Warranty disclaimers:** Any implied warranties arising out of this sale, including but not limited to the implied warranties of description, merchantability and intended operational purpose, are limited in duration to the above warranty period. In no event shall the manufacturer be liable for loss of use of this product or for any indirect, special, incidental or consequential damages, or costs, or expenses incurred by the consumer or any other user of this product, whether due to a breach of contract, negligence, strict liability in tort or otherwise. The manufacturer shall have no liability for any personal injury, property damage or any special, incidental, contingent or consequential damage of any kind resulting from gas leakage, fire or explosion. This warranty does not affect your statutory rights. **Warranty Performance:** During the above warranty period, your product will be replaced with a comparable product if the defective product is returned together with proof of purchase date. The replacement product will be in warranty for the remainder of the original warranty period or for six months – whichever is the greatest.

Information on waste disposal for consumers of electrical & electronic equipment.



When this product has reached the end of its life it must be treated as Waste Electrical & Electronics Equipment (WEEE). Any WEEE marked products must not be mixed with general household waste, but kept separate for the treatment, recovery and recycling of the materials used. Please contact your supplier or local authority for details of recycling schemes in your area.

At the end of their working life, electrochemical sensors for oxygen and carbon monoxide detectors should be disposed of in an environmentally safe manner. Alternatively they can be securely packaged and returned to AGS clearly marked for disposal. Electrochemical sensors should not be incinerated as this may cause the cell to emit toxic fumes.

Installation

Typical Location & Positioning

Our detectors should be installed in safe areas only at risk of gas leaks e.g. over boilers, valves or meters. Take in to account the design of the air flow patterns within the zone area.

Detectors should be installed in the correct orientation, as recommended, and ease of access should be accounted for to allow for any servicing, recalibration and other forms of maintenance.

Consider the coverage required, application and function of the area. Emphasis should be placed on airflow patterns, correct placement and not perceived detection ranges. The target gas will only be identified when contact is made with the sensing element itself.

Maximum Gas Detectors per Merlin Panel

Merlin 'S' Range	1 Detector
Merlin GDP2	6 Detectors (2 Zone Panel – LED Indication)
Merlin GDP4	12 Detectors (4 Zone Panel – LED Indication)
Merlin GDP2X	8 Detectors (2 Zone Panel – Digital Indication)
Merlin GDPX+	16 Detectors (4 Zone Panel – Digital Indication)

Avoid conditions of any other environmental factors that could potentially impede the accuracy and operation of the detectors such as; condensation; vibration; temperature, pressure, the presence of other gases, electromagnetic interference and draft/splash zones i.e. doors, fans, sinks, ovens etc.

Locations for detectors will vary based on the intended application and target gas, they should be located near identified sources of a potential gas leaks/pockets where gas could quickly accumulate and areas of identified consequential risk to detect gas. The composition of the target gas and its density relative to air are used as the basis for the recommended height of sensors. Generally, the installation height of a sensor for a heavy gas (such as propane) would be close to the lowest point in the area, and for a light gas (such as methane) would be close to the highest point in the area. These recommended heights may vary based on air flow and temperature conditions in addition to the proposed application and location – this is particularly apparent with oxygen depletion sensors, and the target gas that they are used for.

Target Gas

- Natural Gas/Methane (NG)
- Liquid Petroleum Gas (LPG)
- Carbon Monoxide (CO)
- Carbon Dioxide (CO2)
- Hydrogen (H)
- Oxygen (O₂)

Typical Position

- High Level - 300mm (1ft) from ceiling
- Low Level - 300mm (1ft) from ground level
- Breathing Zone - 1700mm (5ft 6") from ground level
- Breathing Zone - 1700mm (5ft 6") from ground level
- High Level - 300mm (1ft) from ceiling
- *Breathing Zone - 1000-1500mm (3 - 5ft) from ground level

* If you are installing and monitoring Oxygen depletion – consider the density of gas for its application and position the detector accordingly i.e. ground level for high density gases.

The detectors are designed around a centralised control panel of which the location also needs to be considered.

The control panel should be located away from the area that it is monitoring and accessible is for both status observation and alarm purposes.

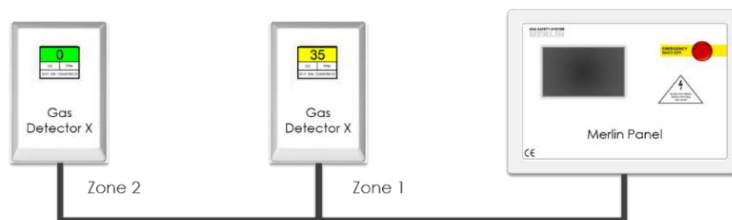

Where cable runs may exceed 100 yards from a control panel – Contact your supplier!

Access & Mounting

Unpack all the parts.

The detectors are designed for surface mounting and must be installed by a licensed, insured contractor or competent person. A deeper back enclosure is supplied to accommodate wiring where required.

Carefully remove the rear cover from the unit by releasing the two latching clips located at the bottom of the case. To do this – use a small flat head screwdriver.

Using the rear cover - mark the screw holes to the wall and ensure the wall surface is flat to prevent base distortion. There are two pre-fractured areas for cable entry provided on the inside of the rear cover which may be cut away as required. After executing the mounting and the connections – replace the rear cover ensuring the two clips are latched.

Make a note of the installation date on the label located on the side of the unit.

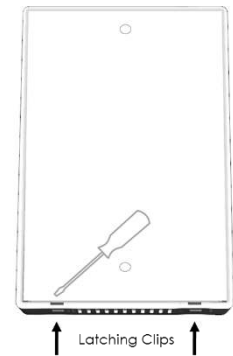

We recommend all Merlin gas detection equipment is commissioned by a competent/trained engineer to ensure correct installation and operation. Contact AGS for more information.

Internal Board Overview

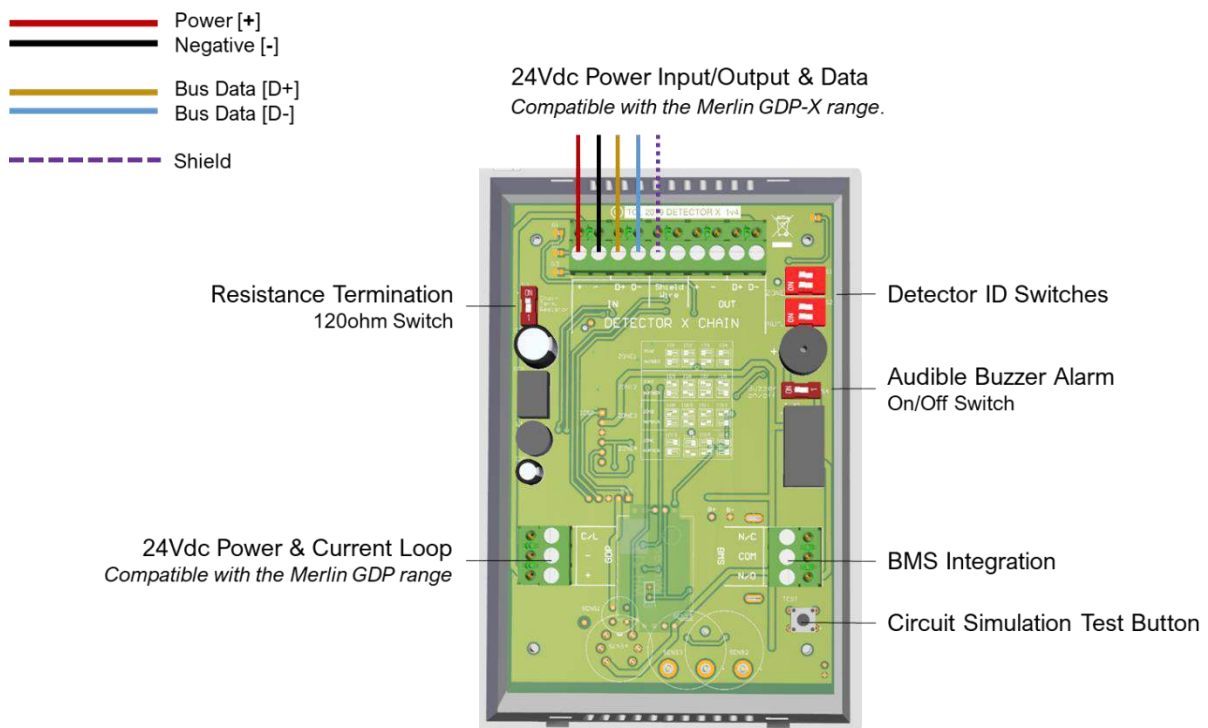

Note: Terminal blocks are plug/socket type and may be removed to ease wiring.



Be careful when creating access for cables – Damage to circuit boards will void any warranty!

Any damage attempting to remove the circuit board parts may void any warranty!

Detectors must be earthed/grounded for electrical safety and to limit the effects of EMC or R/F interference!

For MODBUS communications, a shielded cable is used!

Wiring a Detector (GDP2X or GDPX+ Control Panel)

24vdc power supply from the control panel and communication cables are wired to control panels (GDP2X or GDPX+). Both control panel and detector terminals are marked as [DETECTOR CHAIN + - D+ D-].

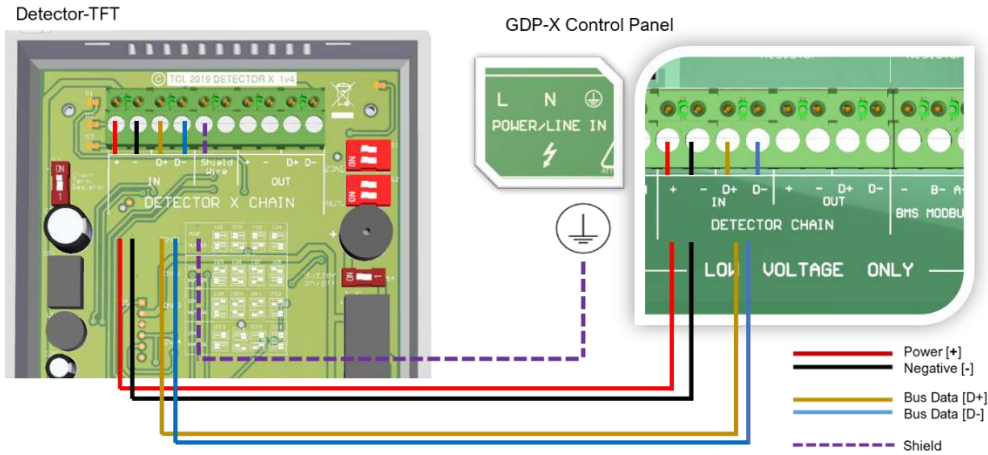

[SHEILD WIRE] detector terminals should be used for earthing/grounding and shield wires connected to any Earth/Ground terminal on the control panel. Twist the shield wire to avoid stray shield wires,

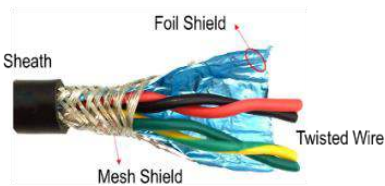

A shielded and twisted 2 or 4 core cable is used to wire the MODBUS terminals [D+ & D-]. The shielding can be of 2 types: braided [mesh of thin conducting wires] or foil (consisting of a thin sheet of metal covering the twisted wires). One example of such cable is BELDEN 3082A. Any cable with similar characteristics can be used to connect all the devices together.

If you are encountering noise or irregular problems with a bus link, the problem is likely related to grounding, incorrect shielding or wiring mains power cables next to data cables.



The detector must be earthed/grounded for electrical safety and limit the effects of R/F & EMC interference!
Where cable runs may exceed 100 yards from one control panel – Contact your supplier!
Ensure the 120-ohm termination resistance switch is turned on at each end of a cable run!

Creating a Detector Chain

Create a detector chain by connecting detectors in a parallel (daisy chain) method. Any other way may cause issues or damage to the overall system. Resistor switches should be turned on at each end of a chain – see section ‘120ohm Termination Resistance’.

Single Detector Chain from Control Panel example.

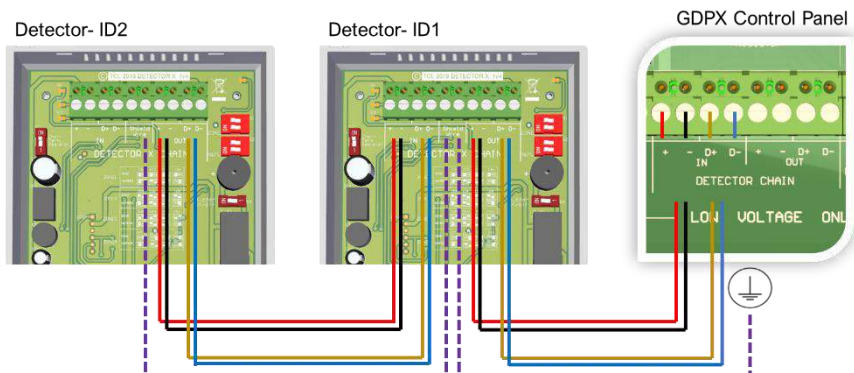

Split Detector Chain from Control Panel example.

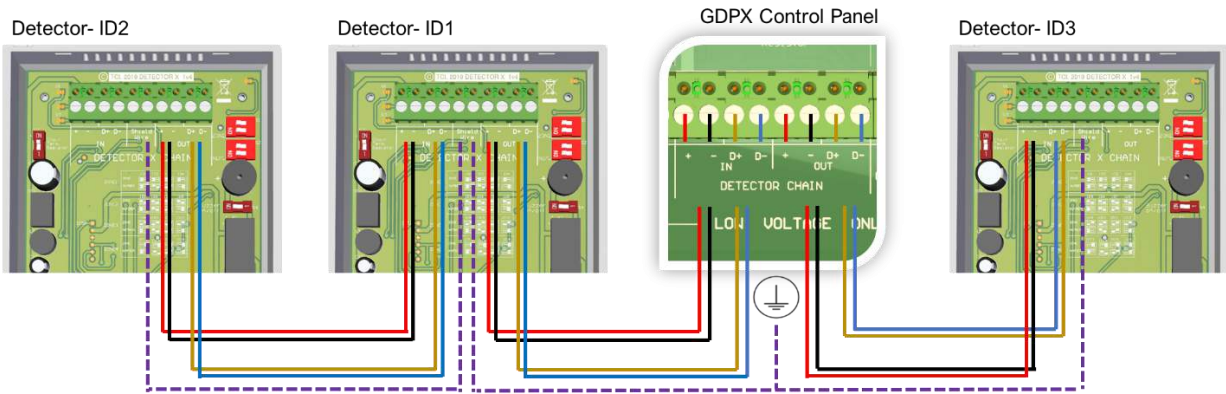

Reversing the [D+] and [D-] connections of any device can lead to the whole system to stop working owing to reverse polarity found on the terminals. In order to avoid this problem, it is recommended that the cable of same colour should be used to connect all [D+] terminals together and similarly cable of same colour to be used to connect all [D-] terminals together.



The detector must be earthed/grounded for electrical safety and limit the effects of R/F & EMC interference! Where cable runs may exceed 100 yards from one control panel – Contact your supplier! Ensure the 120ohm termination resistance switch is turned on at each end of a cable run!

Detector ID Switches

When wiring multiple detectors it is important to identify each detector installed for the control panel to receive and display accurate data corresponding with the correct device.

The ID configuration diagram is printed onto detector boards for quick reference as shown opposite. All detectors are factory set to ID1.



		ID 1	ID 2	ID 3	ID 4
ZONE1	ZONE	<input type="checkbox"/>	<input type="checkbox"/>	<input type="checkbox"/>	<input type="checkbox"/>
	NUMBER	<input type="checkbox"/>	<input type="checkbox"/>	<input type="checkbox"/>	<input type="checkbox"/>
		ID 5	ID 6	ID 7	ID 8
ZONE2	ZONE	<input type="checkbox"/>	<input type="checkbox"/>	<input type="checkbox"/>	<input type="checkbox"/>
	NUMBER	<input type="checkbox"/>	<input type="checkbox"/>	<input type="checkbox"/>	<input type="checkbox"/>
		ID 9	ID 10	ID 11	ID 12
ZONE3	ZONE	<input type="checkbox"/>	<input type="checkbox"/>	<input type="checkbox"/>	<input type="checkbox"/>
	NUMBER	<input type="checkbox"/>	<input type="checkbox"/>	<input type="checkbox"/>	<input type="checkbox"/>
		ID 13	ID 14	ID 15	ID 16
ZONE4	ZONE	<input type="checkbox"/>	<input type="checkbox"/>	<input type="checkbox"/>	<input type="checkbox"/>
	NUMBER	<input type="checkbox"/>	<input type="checkbox"/>	<input type="checkbox"/>	<input type="checkbox"/>



We recommend a plan, map and/or marking the detector enclosures detailing ID and location! ID Switches must be configured for each detector connected to receive and display accurate data!

120ohm Termination Resistance

Signal communication issues may occur where the bus length is too long, high baud rates are used or signal reflections are occurring. To avoid this, terminating at each end of a chain may help the quality of the data signal by turning on the 120-ohm terminal resistor switch. If a split chain is used, terminate the last detector in each chain. If a single chain is used, terminate the first device (Panel) and last device (Detector).

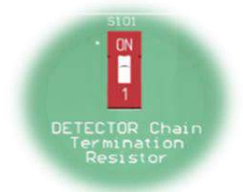

Split chain

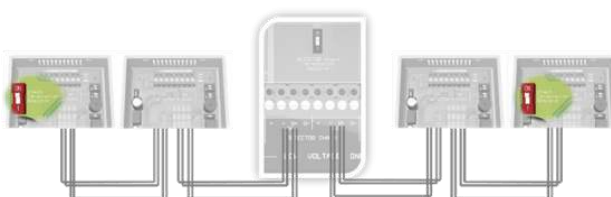

Single chain

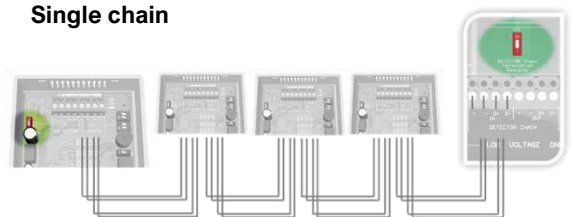

Wiring a Detector (GDP2 or GDP4 Control Panel)

Power is supplied to a detector via the GDP terminal [+ / -] and using the panel [GAS DETECTION ZONE] terminal. If you are using a GDP panel you will need to use the detector [C/L] terminal as an alarm relay.

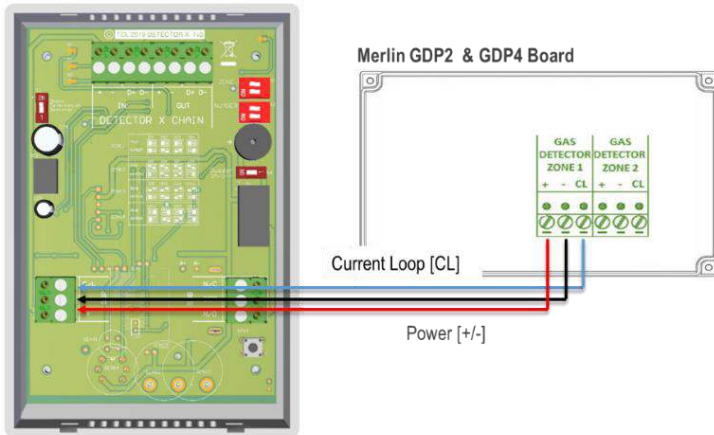

BMS terminals can be used in conjunction with other external relays that affect other devices and controls such as purge fans or audible alarms etc.

Wiring your Detector (Merlin 'S' Control Panels)

Power is supplied to a detector via the GDP terminal [+ / -] and using the 'S' panel [GAS DETECTOR] terminal [+ / -]. For a BMS alarm relay use [COM] and [NC] on the detector and the [open/close] switch terminal on the panel. BMS are volt free connections.

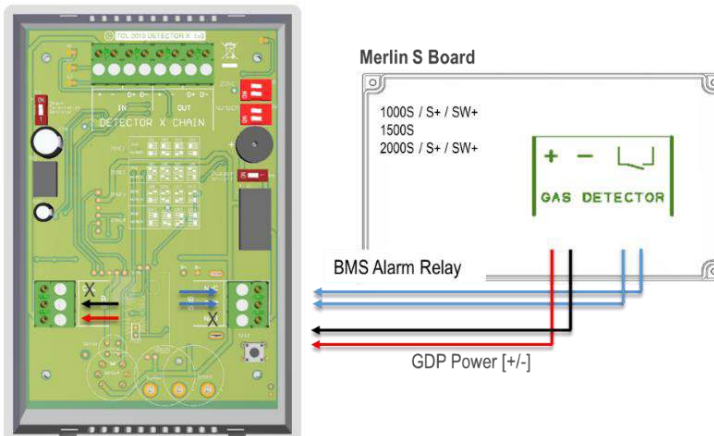

A relay will change state when in alarm or when gas is detected. BMS terminals can be used in conjunction with other external relays that affect other devices and controls such as purge fans and audible alarms etc.

Audible Alarm Switch



There is a switch on the detector board identified as [Buzzer On/Off]. The detector can be configured to have an audible alarm or not when gas levels reach the alarm set points. The alarm will continuously sound – there are no provisions to silence the alarm, gas levels must drop to a safe value for the alarm to stop.

Factory Set Condition

- Buzzer On/Off Switch **ON**
- Chain Termination Resistor **OFF**
- Detector ID Switches **ID 1**

Detectors are shipped pre-calibrated and configured.

Installation Tips

Wiring detector chains

The best way to connect devices in a MODBUS RTU communication is a parallel DAISY CHAIN method.

Cable distance

You may encounter problems when powering detectors beyond 100 yards from one control panel, in this instance, contact your supplier.

Resistance to interference

Signal communication issues may occur where the bus length is too long, high baud rates are used, or signal reflections are occurring. To avoid this, terminating at each end of a chain may help the quality of the data signal by turning on the 120ohm terminal resistor switch of the first and last device in the chain.

Earthing/Grounding

If you are encountering noise or irregular or abnormal problems, the problem is likely related to grounding, incorrect shielding or wiring mains power cables next to data cables. If using a shielded cable – ensure the shielding or equivalent is wired to the [Shield Wire] terminal on the detectors and connected to a mains powered earth/ground point on the control panel.

Cable characteristics

For MODBUS communications, a shielded and twisted pair cable is used. The shielding can be of 2 types: braided [like a mesh of thin conducting wires] or like a foil [consisting of a thin sheet of metal covering the twisted wires].

Detector protection

High concentrations of alcohol found in many products may damage, deteriorate or affect the gas sensing elements of the detectors – such as; wine; deodorants; stain removers; thinners etc.

Detector identification

Remember to individually ID each connected detector by configuring the ID switches on the circuit board. Make a plan, map and/or note of the location of all connected detectors for tracing and locality purposes.

Buzzer on alarm

There are no provisions to silence the alarm buzzer when high gas levels are detected. Gas levels must return to safe level for the buzzer to stop. The audible buzzer is optional via a switch on the circuit board.

Operation

Initial Power-Up (Commissioning)

On connecting power, the detector enters 'sensor stabilisation' phase for approximately 60 seconds – during this period the screen will display an 'initialisation' message indicating that the device is not yet ready for gas detection. After the sensor has stabilised – the screen will display;

- a. Target gas.
- b. Target gas value.
- c. Target gas measurement (parts per million or % LEL).
- d. Unique detector serial/batch number.
- e. Configured ID number.

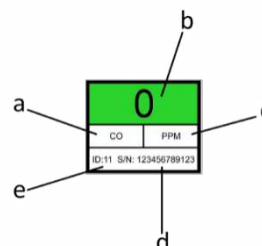

We recommend all gas detection systems be commissioned by a competent/trained engineer to ensure correct installation and operation!

Digital Indication



Alarm Set Points

▲ Rising alarm ▼ Falling alarm LEL (Lower Explosive Limit) PPM (Parts per Million)

Gas Detector	Pre-Alarm	Buzzer	Alarm State	Buzzer
Methane/Natural Gas (NG)	▲ 8% LEL	No Sound	▲ 10% LEL	Continuous sound
Liquid Petroleum Gas (LPG)	▲ 8% LEL		▲ 10% LEL	
Hydrogen Gas (H)	▲ 8% LEL		▲ 10% LEL	
Oxygen (O2)	▼ 19.5% v/v		▼ 18.5% ▲ 23%	
Carbon Monoxide (CO)	▲ 20 PPM		▲ 20ppm after two (2) hours ▲ 50ppm after One (1) hour ▲ 100ppm after Ten (10) minutes ▲ 300ppm after One (1) minute	
Carbon Monoxide (CO) TFT 'FL' Type Only	▲ 20 PPM		▲ 35ppm	
Carbon Dioxide (CO2)	▲ 2800 PPM		▲ 4500 PPM	

⚠ An audible buzzer will sound if the buzzer switch on the circuit board is on!

General Maintenance

Cleaning

- ⚠ **Concentrations of alcohol found in many products may damage, deteriorate or affect the gas sensing elements such as; wine; deodorants; stain removers and thinners. Other gases and substances to avoid are corrosives (i.e. chlorine & hydrogen chloride); alkali metals; basic or acidic compounds; silicones; tetraethyl lead; halogens and halogenated compounds!**

Keep your gas detector in good working order - follow these basic principles.

- Remove any dust/debris from the outer enclosure regularly using a slightly damp cloth.
- Never use detergents or solvents to clean your device.
- Never spray air fresheners, hair spray, paint or other aerosols near the device.
- Never paint the device. Paint will seal vents and interfere with the device.

Manual Circuit Simulation Test

- ⚠ **Access to the interior of the detector, when carrying out any work, must be conducted by a competent person!**
- ⚠ **This circuit test does not check the gas-sensing element itself!**

When the test button on the circuit board is pressed and held the detector will simulate an open circuit to ensure configured systems, outputs, alarms, indications, and other external devices operate as intended in response to gas. When the test button is released – the test sequence will terminate and return to normal operation.



Service Reminders



A service screen will intermittently flash every 30 seconds after one year of operation.

The annual message reminder will begin after five (5) hours of continuous power irrespective of whether the system is then, used intermittently. The detector will still operate as intended during this time.

Depending on the application and environmental factors, a service (bump test) can be conducted at a higher frequency determined by the end user but must be executed by a competent person.

Bump Test (Gas Response Check)

What is a Bump Test?

Gas response checks are often referred to as a 'bump test'. Bump tests are important to make sure a device is able to detect a release of gas as early as possible. The aim of the bump test is to make sure a detector is working at its optimum by briefly exposing the unit to a known concentration of the target gas that usually exceeds the highest alarm point. If the detector goes into alarm and all signals/outputs activate, then the system is working safely.

If the system fails to operate as intended in an alarm state, the gas detector must not be used until a full inspection and service has been conducted. NFPA requires all gas detectors to be tested annually and that the test results be recorded on site and available to inspectors.

Why is it important?

A detector may visually appear in good working order, but its sensitivity and accuracy can be inhibited by external factors. Dust, humidity, temperature fluctuations, cleaning products, contaminants, exposure to its target gas or sensor drift (ageing) can cause a decline in sensitivity, accuracy and eventual failure.

How often?

Regular bump tests are important to make sure the detector is able to detect a release of gas as early as possible and usually takes seconds (gas type dependant i.e. CO sensors will take over a minute) and is often completed alongside a scheduled fire alarm test, however the frequency should be determined following an appropriate risk assessment by the end user.

We recommend testing detectors every 12-18 months along with the regular fire test procedures and coincide with the annual service message prompted on the detection system after each year of service/operation.

What do I need?

Contact your AGS representative for details of suitable bump testing kits and gases. Kits usually consist of a certified gas cylinder or spray. We recommend only using AGS calibration gas kits to ensure correct flow rates meet AGS technical requirements. A bump testing gas is usually a concentration mix that exceeds the highest alarm set point.

Standard Test Gases

⚠ All certified test gases supplied by AGS are classified as non-flammable and non-toxic, however, they do contain gas under pressure and may explode if heated to extreme temperatures and cause asphyxiation in high concentrations.

See below for recommended gas concentrations for bump testing your detector.

Detector Type	Standard Test Gas
CO - Carbon Monoxide	350 - 500ppm (balance in air).
NG - Methane	0.6 - 0.8% BV (balance in air)
LPG - Liquid Petroleum Gas	0.3 – 0.4% BV (balance in air)
H - Hydrogen	5000 - 6000ppm (balance in air)
O ₂ - Oxygen	15% (balance in Nitrogen).
CO ₂ – Carbon Dioxide	>4500ppm or Breath on Sensor

Bump Test Procedure

- ⚠ To increase reaction time, cover the escape vents at the top of the device.
- ⚠ For more help and advice on bump testing – contact us.
- ⚠ Always remove the regulator/valve from cylinder after use!
- ⚠ Always check cylinder pressure upon sealing valve – there may not be a sufficient amount of gas!
- ⚠ All AGS cylinders will re-seal upon removal of the regulator/valve!
- ⚠ Always give at least five (5) minutes between testing the same unit or until gas has fully dispersed!
- ⚠ Always consider safety and use equipment in accordance with Safety Data Sheets!

STEP 1

Activate Controller Service Mode – GDP2X & GDPX+

- ⚠ This will inhibit all alarms/outputs and signals for fifteen (15) minutes!
 - ⚠ If you are testing all actuation of alarms/outputs and signals please proceed to Step 2!
- Access service mode by pressing the AGS logo on the controller (home screen logo only).
 - The screen will display a service message prompt.
 - Press Yes. (Note: All alarm signals/outputs will be inhibited for fifteen (15) minutes).
 - Proceed to test gas detectors.
 - Upon completion – exit service mode by pressing the ‘Exit’ button on screen.



STEP 2**Test Detector**

⚠ Access to the interior of the detector, when carrying out any work, must be conducted by a competent person!

- Ensure you have the correct gas for the device type prior to application.
- Screw and seal the regulator/valve into the gas cylinder outlet.
- Once sealed, the regulator pressure gauge will indicate cylinder pressure.
- Offer up the applicator hose/cone to the lower vents.
- Alternatively, enclose the device and apply gas i.e. in an airtight bag or container.
- Open the valve/regulator to allow the gas to be delivered at a pre-set flow rate.
- Wait for the device to enter alarm status and energise configured outputs/relays.
- At this point...
- Remove applicator hose/ cone and turn the gas cylinder regulator/valve off.
- Wait for the device to return to normal.
- Reset the system.
- Record your test details. There is a provision for this in your control panel manual.

End.



Reset Service Message

⚠ Access to the interior of the detector, when carrying out any work, must be conducted by a competent person!

⚠ It is recommended to bump test detector(s) prior to resetting the service reminder message!



1. Carefully remove the detector cover to access the circuit board.
2. Short out the unmarked service header for ~5s and wait for a 'beep'.
3. The service message on screen will reset.
4. Carefully replace the back cover.

End of Operational Life (EOL)

⚠ The EOL is approximate from the first five (5) hours of continuous power!

⚠ The EOL will depend on the type of gas your detector is targeting and may vary depending on its application and environmental conditions such as the frequency of exposure to the target gas, poisons or inhibitors!



The typical life of a gas detector depends on its application and intended target gas, in addition the operational life can be prolonged if the system and equipment is installed and maintained in accordance the instructions stated within this manual.

At the end of its predicted operational life – the detector will display an 'End of Life' screen. This message indicates that the detector has reached its expected operational lifecycle and no gas levels are displayed.

You must contact your supplier immediately for replacement.

Page intentionally left blank.

Technical Specification

General							
Model:	Merlin Gas Detector TFT & TFT-FL						
Target Gases:	CO/LPG/NG/O2/H/CO2						
Size: (H x W x D)	5.51 x 3.74 x 1.18" (140 x 95 x 30mm)						
Housing Material:	ABS Polylac - PA765						
Mounting:	Safe Zone - Indoor use - Wall Mounted						
Weight:	Max. 1.77oz (0.05kg)						
User Interface							
Display:	1.8" TFT						
Screen Brightness:	Non-Adjustable						
Visual Indicators:	TFT visual. Green: Normal; Yellow: Pre-Alarm; Red: Alarm						
Audible Alarm:	>70dB @ 3.28ft (1m). Quiet conditions.						
Buttons:	None						
Language:	English						
Power Supply							
Power Consumption:	90mA Max @ 24vdc						
DC Power:	12-32 VDC - Nominal 24 VDC						
Internal Fuse:	None						
Equipment							
Overvoltage Category:	III						
Pollution Degree:	3						
I/O							
Relay:	Volt Free (Normally Closed / Common / Normally Open) 1x 30vdc 2A (Non-Latching)						
Environmental							
Ingress Protection:	Not Formally Evaluated						
Operating:	-10 ~ 50°C / 14 ~ 122°F 30 ~ 80% RH (non-condensing)						
Storage:	-25 ~ 50°C / -13~122F° up to 95% RH (non-condensing)						
Altitude Rating:	2000m						
Wiring							
Typical	#15AWG Power Pair; #18AWG Data Pair-Tinned copper.						
Approvals							
Electromagnetic Compatibility and Electrical Safety	BS/IEC/EN 61010-1 EMC EN 50270						
Other							
Communication	RS485 MODBUS RTU						
Sensor Specification							
Gas Sensor	Indicating Range	Steps	Response (t90)	Recovery (t10)	Alarm: 1 (Pre alarm warning)	Alarm: 2	*EOL (Years)
Electrochemical Sensors							
Carbon Monoxide (CO)	0-999ppm	1	<60s	<60s	▲20ppm	Exposure time. ▲20ppm (after two hours) ▲50ppm (after one hour) ▲100ppm (after ten minutes) ▲300ppm (after one minute)	5
Carbon Monoxide (CO) TFT'FL' Type Only	0-999ppm	1	<60s	<60s	▲20ppm	▲35ppm	5
Oxygen (O ₂)	0-30% V/V	0.1	<30s	<60s	▼19.5% V/V	▼18.5% V/V ▲23% V/V	2
Semiconductor Sensors							
Methane (CH ₄)	0-20% LEL	0.1	<30s	<30s	▲8% LEL	▲10% LEL	10
Propane (LPG)	0-20% LEL	0.1	<30s	<30s	▲8% LEL	▲10% LEL	10
Hydrogen (H)	0-20% LEL	0.1	<30s	<30s	▲8% LEL	▲10% LEL	10
NDIR. Intelligent Infrared CO2 Module. ABC Logic Auto Calibration							
Carbon Dioxide (CO ₂)	400-5000ppm	1	<30s	<30s	▲2800ppm	▲4500ppm	10

▲ Rising Alarm ▼Falling alarm *EOL – Expected Operational Life

Installation Details

Please pass this manual to the system owner / user.

Date of Installation:	
Installation Location:	
Organisation:	
Stamp/Signature of the installer:	

We recommend all Merlin gas detection equipment be commissioned by competent/trained engineers to ensure correct installation and operation. The Merlin range of gas detectors are calibrated when manufactured, however, we strongly recommend the detectors response and alarm signals are tested and validated once installed. This will ensure the equipment performs as intended and is free from any unforeseen damage caused by transit/installation.

Every effort is made to ensure the accuracy of this document; however, AGS can assume no responsibility for any errors or omissions in this document or their consequences. AGS would greatly appreciate being informed of any errors or omissions that may be found in the content of this document. For information not covered in this document, or if there is a requirement to send comments/corrections, please contact AGS using the contact details given below.

American Gas Safety LLC**Head office:**

6304 Benjamin Road, Suite 502, Tampa, FL 33634

Tel: (727) 608-4375

info@americangassafety.com



American Gas Safety LLC is the owner of this document and reserves all rights of modification without prior notice.