

AGSNO2PS Datasheet

Nitrogen Dioxide ParkSafe Detector



24VDC Power Input



Used With The
 ParkSafe Controller



Traffic Light
 Indicator Display
 Changes Color
 Dependent On Gas
 Levels



BMS
 Communications



Modern & Compact
 Design



Up To 16 Detectors
 Can Be Linked Together



Plug & Play
 Installation



End of Operational Life
 & Annual Service
 Notifications to
 ParkSafe Controller

Product Overview

The AGS PS range of detectors work in combination with the AGS ParkSafe, a Gas Detection & Ventilation Controller specifically designed for Parking Garage CO & NO2 monitoring. The AGSNO2PS features a electrochemical sensor for industrial and commercial indoor applications. Compact, modern, digital design makes the units aesthetically pleasing and easy to install.

Popular Applications

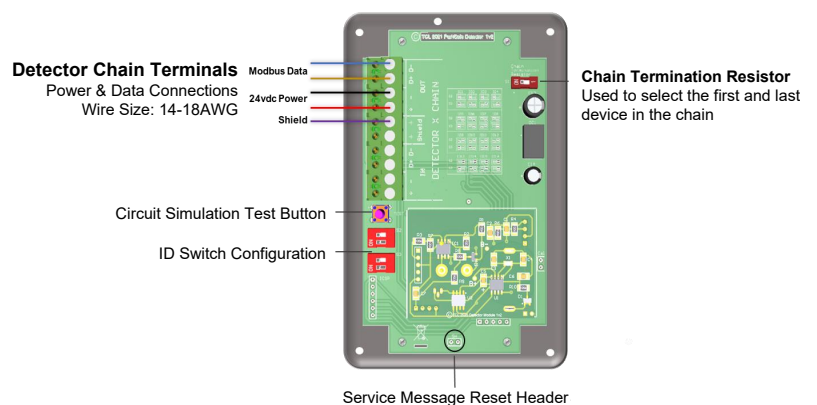

Technical Specification

General							
Model:	ParkSafe Detector						
Gases:	Nitrogen Dioxide						
Size: (H x W x D)	4.92 x 3.15 x 1.38"						
Housing Material:	ABS						
Mounting:	Wall Mounting – No limits - Non-Hazardous Areas						
Weight:	1.6oz						
User Interface							
Display:	LED						
Visual Indicators:	Power / Alarm / Fault						
Audible Alarm:	None						
Power Supply							
Power Consumption:	15mA Max @ 24Vdc						
DC Power:	12-32Vdc (24vdc Nominal)						
Internal Fuse:	N/A						
Equipment							
Pollution Degree:	2						
Equipment Class:	2						
Environmental							
Ingress Protection:	Not Formally Evaluated						
Operating:	-10 ~ 50°C / 14 ~ 122°F 30 ~ 80% RH (non-condensing)						
Storage:	-25 ~ 50°C / -13~122F° up to 95% RH (non-condensing)						
Altitude Rating:	2000m						
Wiring							
Typical	Copper 18AWG (0.75mm ²) Min. 8x screw terminals.						
Other							
Communication	RS485 MODBUS RTU						
Sensor Specification							
Factory Calibration Conditions	25° ± 5°C - 77° ± 41°F (40-70% RH)						
Sensor Type	Electromechanical						
Gas Sensor	Measuring Range (ppm)	Calibration Gas	Response (T90)	Recovery (T10)	Alarm: 1 (Pre alarm warning)	Alarm: 2	*EOL (Years)
Nitrogen Dioxide (NO ₂)	0-20	5ppm NO ₂	<60s	<50s	▲0.7ppm	▲2ppm	3



Area of coverage

Consider the coverage required and function of the area. Each AGSNO2PS can cover a 50ft radius. Emphasis should be placed on airflow patterns and correct placement, not perceived detecting ranges.

The AGSNO2PS monitor should be installed approximately 4-5ft from the ground level.

Find out more

American Gas Safety LLC

www.americangassafety.com

Head office:

6304 Benjamin Road, Suite 502, Tampa, FL 33634

Tel: (727) 608-4375

Email: info@americangassafety.com

