

AGSCO2X Datasheet

Carbon Dioxide & Temperature Monitor



- Dual Power**
100-120V AC OR
12-24V AC / DC
- Automatic Drive**
Ventilation Fans To
Reduce CO2 /
Temperature
- Modern &
Compact Design**
- Plug & Play**
Installation
- Clear TFT Screen**
Displays Live Gas
Levels & Status
Indications
- BMS & Fire Panel**
Connectivity
- Three Alarm**
Relays &
0-10VDC Output
- Boost, Mute &
Wake Up Button**

Product Overview

The AGS CO2 X is designed to monitor carbon dioxide (CO2) in the air, local temperature and can be used to provide not only a clean breathing air environment but also an energy saving solution. The AGS CO2 X Monitor is a wall mounted CO2 and temperature monitor that provides precise, easy to read measurements in a single device. Using relays and 0-10vdc outputs the unit can interface with all modern BAS systems. The continuous CO2 self-recalibration feature eliminates the need for routine maintenance.

Popular Applications

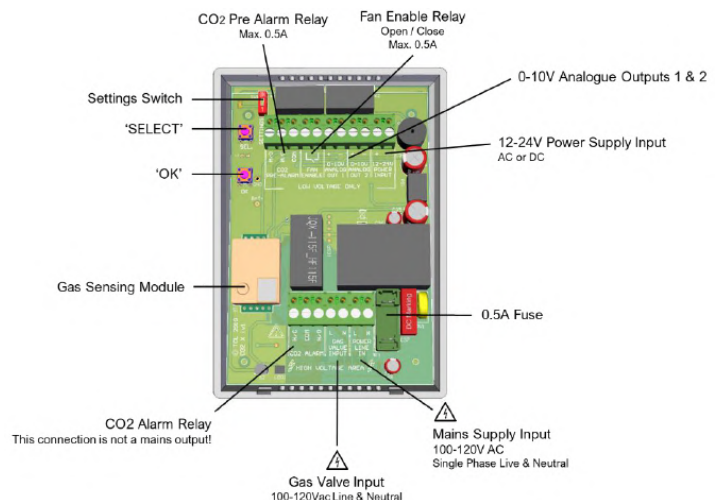



Circuit Board Overview

General								
Product:	CO2-X							
Indicators (1.8" TFT Screen)	Green (Safe), Yellow (Special State) & Red (Alarm). Detected CO2 Level. Time Weighted Average CO2 Level (TWA). Temperature. Mute. Ventilation Boost Active. End of Life.							
Screen Brightness	Low – Medium – High (Plus Screen Saver)							
Mounting	Wall Mounting							
Electrical								
Max. Power Consumption	2.16W							
Power Voltage Input Range	110-120V AC 50-60Hz or 12-24V AC/ DC (Nominal 24V AC/DC Max)							
Gas Valve Input	100–120vac							
CO ₂ Pre Alarm Relay Output	Max 0.5A Signal							
CO ₂ Alarm Relay	Max 3A @ 240V							
Fan Enable Relay Output	Max 0.5A Signal							
Terminal Wire ratings	Copper 18AWG (0.75mm ²) Min. 14 x screw terminals.							
Internal Fuse	0.5A / 250V AC							
Construction								
Dimensions (H x W x D)	140 x 95 x 30mm / 5.51 x 3.74 x 1.18"							
Unit Weight (Approx.)	0.08kg							
Housing Material	Polylac - PA765							
Environmental								
Ingress Protection	IP40							
Storage Conditions	Dry. Temp: -10 ~ 50°C / 14~ 122°F : 30 ~ 80% rh							
Compliance								
CE	EN 50270 / EN 61010-1							
Temperature Sensor Specification								
Sensor Type	Linear Active Thermistor Integrated Circuit							
Measuring Range	0-95 °C / 0-203°F							
Accuracy @ 25°C / 77°F	± 2°							
Resolution	0.1 °C/°F							
Carbon Dioxide Sensor Specification								
Factory Conditions	25° ± 5°C - 77° ± 41°F (40-70% RH)							
Sensor Operating Temperature	-10°C ~ 50°C (14 ~ 122°F)							
Sensor Operating Humidity	Continuous 30-80% rh Non-Condensing							
Sensor Operating Pressure	Normal Atmospheric Pressure ± 10%							
Gas Sensor	Indicating Range	Steps	Accuracy	Response (t90)	Ventilation	Alarm: 1 (Pre alarm relay)	Alarm: 2 (Latching relay)	*EOL (Years)
NDIR. Intelligent Infrared CO2 Module. ABC Logic Auto Calibration								
Carbon Dioxide (CO2)	400-5000ppm	1	±100ppm	<90s	Kitchen	▲ 2800ppm	▲ 4500ppm	10
					Natural	▲ 1300ppm	▲ 1500ppm	
					Mechanical	▲ 800ppm	▲ 1000ppm	

Area of coverage

Consider the coverage required and function of the area. Emphasis should be placed on airflow patterns and correct placement, not perceived detecting ranges. The target gas will only be identified when contact is made with the sensing element itself.

Your monitor should be installed in populated areas that risk high concentrations of CO2 gas or varied temperatures e.g. educational and government building including laboratories and commercial kitchens.

Find out more

American Gas Safety LLC

www.americangassafety.com

Head office:

6304 Benjamin Road, Suite 502, Tampa, FL 33634

Tel: (727) 608-4375

Email: info@americangassafety.com

