



Product Overview

AGS solenoid gas valves control the flow of natural and LP (liquefied petroleum) gases and are suitable for use on furnaces, ovens, atmospheric burners, commercial water heaters, rooftop make-up air units, power burners and commercial/industrial boilers. Most commonly they are used with our range of utility controllers and gas detection systems.

Key Features

- Normally closed valves offer safety shut off with fast-open, fast-close operation.
- Normally open valves function as vent valves for double block and bleed gas valve trains with fast-close, fast-open operation.
- Positive close-off prevents gas from entering the burner when primary safety control turns burner off.
- Rugged design and construction.
- Valves available in sizes from 3/8" to 3".
- Body material - Die cast aluminium

Valve Size Inches NPT	AGS PART NUMBER 0-2PSI	AGS PART NUMBER 0-5PSI
3/8**	MERLIN1007**	MERLIN1098**
1/2**	MERLIN1015**	MERLIN1106**
3/4	MERLIN1023	MERLIN1114
1	MERLIN1031	MERLIN1122
1+1/4	MERLIN1049	MERLIN1130
1+1/2	MERLIN1056	MERLIN1148
2	MERLIN1064	MERLIN1155
2+1/2	MERLIN1072	N/A
3	MERLIN1080	N/A

****Not to be used with the gas pressure transducer**

Gas Safety Systems

Utility Control

American Gas Safety, LLC. 6304 Benjamin Road, Suite 502, Tampa, FL 33634 T.(727) 608-4375 www.americangassafety.com

Maximum Pressure:

Voltage/Frequency	Maximum Pressure		Pipe Size (inch)	Thread Type
	PSI	mbar		
110/120 Vac, 50/60 Hz	2.0	140	3/8, 1/2, 3/4, 1, 1-1/4, 1-1/2, 2, 2-1/2, 3	NPT
110/120 Vac, 50/60 Hz	5.0	350	3/8, 1/2, 3/4, 1, 1-1/4, 1-1/2, 2	NPT

Dimensions

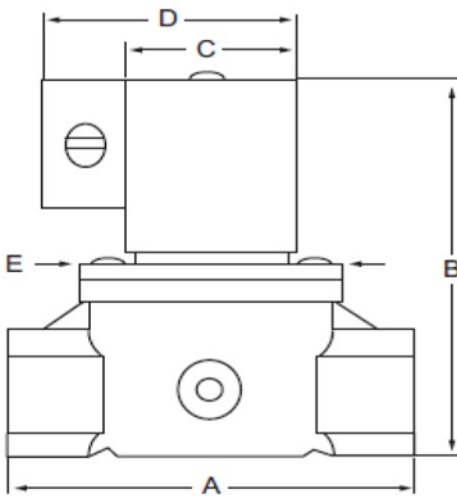

Current Draw

Normally Closed (N/C) Pipe Size (inch)	120 Vac	
	2 psi	5 psi
3/8 and 1/2	0.160 A	0.160 A
3/4 and 1	0.160 A	0.200 A
1-1/4	0.340 A	0.550 A
1-1/2	0.300 A	0.550 A
2	0.525 A	0.540 A
2-1/2	0.575 A	n/a
3	0.675 A	n/a

Pipe size	A (inch)	B (inch)		C (inch)		D (inch)		E (inch) (both sides)	Weight (lbs)	
		2 psi	5 psi	2 psi	5 psi	2 psi	5 psi		2 psi	5 psi
3/8 in. NPT	2-7/8	4-7/16	4-7/16	2-3/16	2-3/16	3-3/4	3-3/4	2-3/16	2.5	2.2
1/2 in. NPT	2-7/8	4-7/16	4-7/16	2-3/16	2-3/16	3-3/4	3-3/4	2-3/16	2.5	2.2
3/4 in. NPT	3-7/16	5-1/4	5-13/16	2-3/16	2-1/2	3-3/4	4-1/16	2-3/4	4.0	4.4
1 in. NPT	3-15/16	5-1/4	6-5/16	2-3/16	2-1/2	3-3/4	4-1/16	3	4.5	4.4
1-1/4 in. NPT	5-15/16	8	8-9/16	2-1/2	3-5/16	4-1/16	4-15/16	4-3/8	12.8	10.6
1-1/2 in. NPT	5-15/16	8-3/8	8-9/16	3-3/8	3-5/16	4-15/16	4-15/16	4-3/8	12.8	10.6
2 in. NPT	6-11/16	8-3/8	9-3/16	3-3/8	3-3/4	4-15/16	5-5/16	5-3/8	14.0	13.4
2-1/2 in. NPT	9-1/2	12-3/4	—	4-9/16	—	6-1/8	—	7-7/8	28.5	—
3 in. NPT	9-1/2	12-3/4	—	4-9/16	—	6-1/8	—	7-7/8	31.0	—

INSTALLATION

When installing this product

1. Read these instructions carefully. Failure to follow them could damage the product or cause a hazardous condition.
2. Check the rating given in the instructions and on the product to make sure the product is suitable for your application.
3. Installer must be a trained, experienced, flame safeguard control technician.
4. After installation is complete, please see product operation information as provided in these instructions.

CAUTION

1. Turn off gas supply before starting installation.
2. Disconnect power supply before beginning installation to prevent electrical shock and equipment damage.
3. Do not remove seal over valve inlet or outlet until ready to connect piping.

Prepare piping and install valve (Fig. 5)

1. Use new, reamed pipe which is free from chips and damage.
2. Do not thread pipe too far.
3. Apply good quality pipe dope resistant to the action of LP gas, putting a moderate amount on the male threads only. If pipe dope lodges on the valve seat, it will prevent full closure.
4. Install valve in a horizontal pipe line, (refer to Fig. 5 for mounting position) with the gas flow matching the direction indicated by the arrow on the casting.
- 5) Apply a parallel jaw wrench only to the wrench flats of the valve body, next to the pipe being inserted. A wrench applied to the valve body itself or to the end furthest from the pipe being inserted may distort the casting, resulting in malfunction on the gas valve.
6. The gas flow must be in the same direction as the arrow on the body of the valve.

Approvals

- > Underwriters Laboratories, Inc., File Number MH 18476, Guide number YLOZ—UL429
- > AGA and CGA, File Number C2030014
- > Complies with standard ANSI Z21.21-CGA6.5
- > Automatic Valves for gas appliances and automatic safety shut-off gas valves (revised edition of the former ANSI Z21.21., CAN,CGA-6.5-M89, CAN/CGA-3.9-M87)

Gas Safety Systems

Utility Control

American Gas Safety, LLC. 6304 Benjamin Road, Suite 502, Tampa, FL 33634 T.(727) 608-4375 www.americangassafety.com

WARNING

If the flow is not in the same direction of arrow, valve may not shut off.

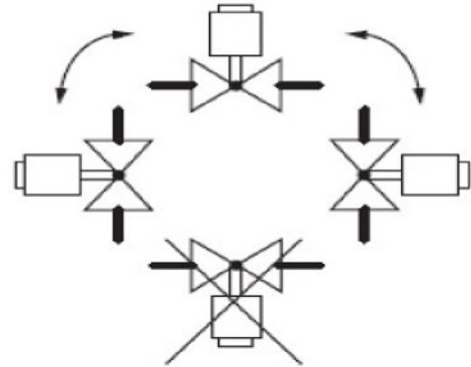

Fig. 5. Mounting position.

7. Make electrical connections as illustrated in the wiring diagrams.
8. Turn on main gas and with a soap solution, check valve installation for leaks.

WIRING

1. Disconnect power supply before making wiring connections to prevent electrical shock and equipment damage.
2. Installation and wiring must be in conformance with National Electrical Code ANSI/NFPA 70, local codes and regulations.
3. For normal installations, use moisture-resistance No. 14 wire suitable for at least 167F (75C) if using a Flame Safeguard Primary Control, or 194F (90C) if using a Flame Safeguard Programming Control.
4. For high temperature installations, use moisture resistant No. 14 wire selected for a temperature rating above the maximum operating temperature.
5. Check the power supply circuit. The voltage and frequency must match those of the valve.