



Merlin 1000S+i

Gas & Electric Utility Isolation Controller



Installation & Operation Manual

Please read this manual carefully and retain for future use.

The Merlin 1000S+i utility isolation controller is designed to give full control over incoming gas supply and electrics with the lockable main key-switch and touch sensors. Suitable for applications such as schools, laboratories, fire houses and more.

Contents

INSTALLATION	3
Planning.....	3
Fixing - Mounting.....	3
Typical Installation Arrangement	4
Terminal Connections.....	4
Switch Settings.....	7
Specification	9
OPERATION	10
First Power Up	10
Emergency Shut Off Button	10
LED Indicators.....	10
Servicing & General Maintenance	12
Bump Testing	12
IMPORTANT WARNING STATEMENTS	13
Manufacturer's Warranty.....	13
Installation Details.....	16

INSTALLATION

Planning

The Merlin 1000S+i is to be used as an isolation utility controller that controls gas supply and electric through a solenoid valve or contactor. If the controller is in alarm condition both gas and electric will be isolated and only re-energize once the fault has been cleared.

The key switch operation of the panel ensures the operator has full control over the room. With its clear LED status display, lockable switches and the Time Out function the unit ensures full protection for the building and the people inside them.

The Merlin 1000S+i can work in conjunction with carbon dioxide, natural gas, carbon monoxide and LPG sensors and also has a built in "timeout" facility which will automatically shut off the utilities at the end of a specific time period, this time period can be adjusted to 2, 5, 8 hours or can be overridden if required.



Please refer to your detector manual for important information regarding coverage, location and positioning including areas and conditions to avoid.

Fixing - Mounting

Unpack all the parts!

Place the panel 48-60 inches above finished floor level for ADA compliance.

1. Carefully remove the front cover from the unit by unscrewing the four bolts located at each corner. To do this – use the socket wrench provided.
2. Mark the four screw holes located on the back of the enclosure to the wall. Ensure the wall surface is flat to prevent base distortion.
3. After executing the mounting and the connections – replace the front cover and insert the security caps over the four bolts.



Be careful when creating access for cables – Damage to boards will void any warranty.
Carefully remove the circuit board before drilling cable entry holes.

A flush mount kit is available, comprising of a mounting bracket and decorative surround strip. Contact your supplier for more information.

Typical Installation Arrangement

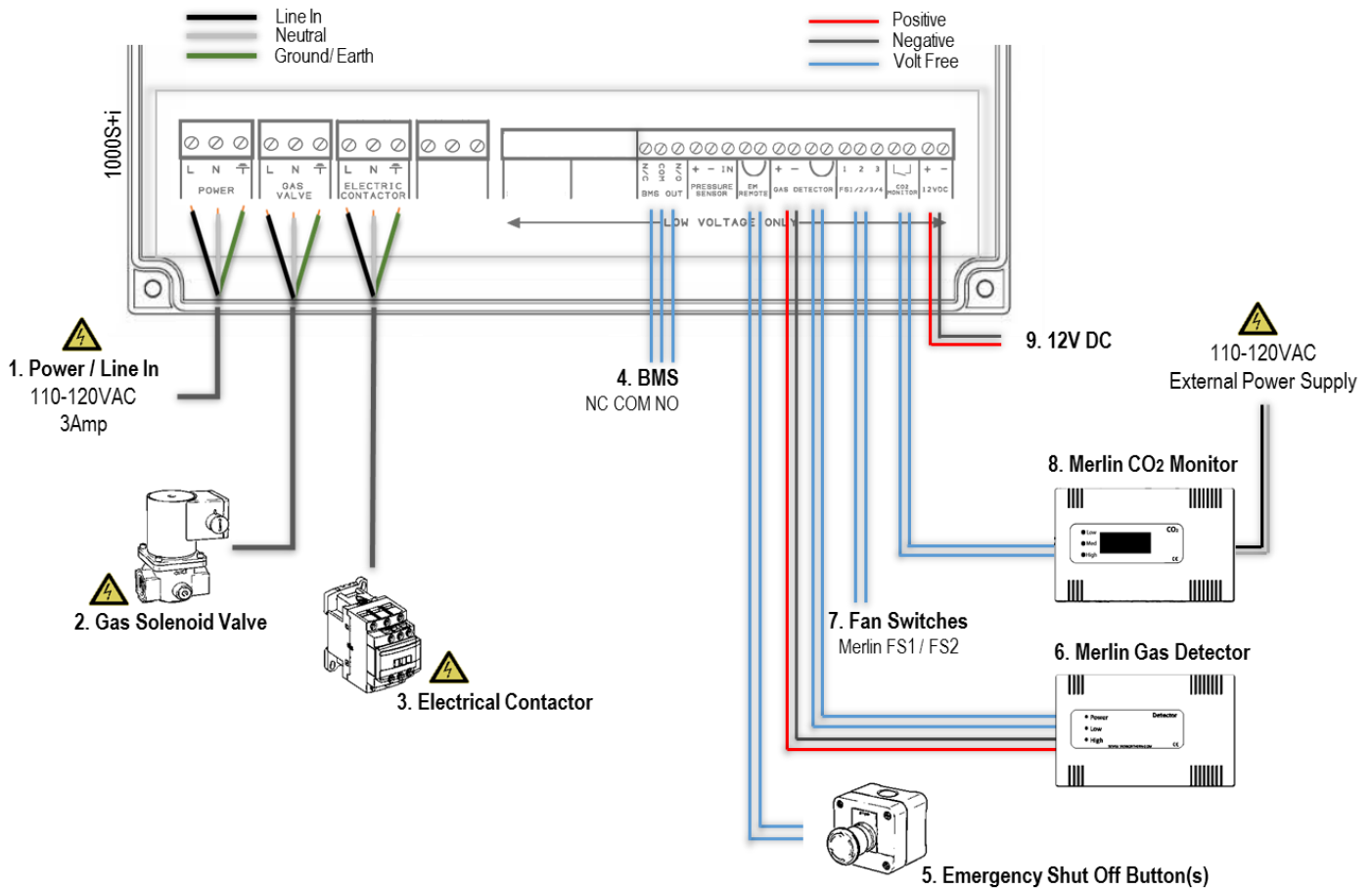

Terminal Connections

1. POWER / LINE IN

110-120V AC Power should be supplied to the [POWER / LINE IN] terminal and fused at 3A.

On connecting the mains supply to the panel the power LED indicator will light up – this is located on the front cover (American Gas Safety Logo).

2. GAS SOLENOID VALVE OUTPUT

100-120V AC electrical power supplied from the [VALVE OUT] connector using a 3 core cable can be connected to a gas solenoid valve which can shut the gas supply on alarm status.

Refer to your valve manual for more information and wiring!

3. ELECTRIC CONTACTOR OUTPUT

100-120V AC electrical power supplied from the [ELECTRIC CONTACTOR] connector using a 3 core cable can be connected to a contactor.

Refer to your contactor manual for more information and wiring!

4. BMS OUTPUT

Connections are available on the board for Building Management Systems.

[NO Normally Open] [COM Common] [NC Normally Closed]
These are volt free connections.

This is a relay that changes state in alarm or when the gas is on/off and can be used in conjunction with the 12V DC output and other external relays that affect other devices and controls such as purge fans and audible alarms etc.

See section; Switch Settings - for BMS options

5. EM REMOTE

Connections for remote emergency shut-off or stop buttons is detailed on the circuit board as [EM REMOTE]. This is linked out as a factory setting.

Remote emergency shut-off buttons should be volt free and wired to the Merlin 1000S+i using a plenum security cable, white, 18/2 (18AWG 2 conductor), stranded, CMP or similar.

6. GAS DETECTOR

Connections can be made for a Merlin gas detector (LPG, NG, CO or Hydrogen).
If no detector is being used leave the factory fitted link in.

A wiring example is shown.

Refer to your gas detector manual for further information.

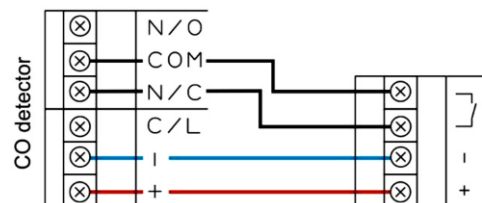

7. FAN SWITCHES

This terminal switches when the key is turned on and off.

This can be connected to a fan switch (supplied separately) which can provide power to fans when the control panel is switched on.

8. CO2 MONITOR

This terminal can be used to connect a Merlin CO₂ monitor to shut off the system in the event of a high concentration of CO₂.

If no CO₂ monitor is connected, the panel will 'beep' upon power up and the CO₂ LED will flash 3 times to indicate that this terminal has been disabled.

An external power supply is required.

Refer to your CO₂ monitor manual for further information.

9. 12V DC

This is a power output for external auxiliary devices when there is power at the panel and can be used to create a relay switch with the BMS relay output.

Max output: 50mA

Switch Settings

There are various dip-switches on the front circuit board that can be adjusted to configure your system as per the following.

Auto Reset

There is a switch located on the circuit board labelled [AUTO RESET].

OFF	When power is restored after the power cut/ loss, the panel has to be restarted manually. (Default)
ON	This will instruct the system to restart automatically when power is restored after power cut/loss.



Building Management System Integration

There is a dip-switch located on the circuit board labelled [BMS SEL].

The panel can be integrated with a BMS to make or break a circuit when the gas is either on or off, (valve open or valve closed). This will tell the BMS whether or not power is being sent to the solenoid valve.

OFF	Signals the BMS when gas is on or gas is off. (Default)
ON	Signals the BMS on a fault, i.e. high gas levels detected, emergency shut-off activated, etc.



Fan Switch Integration

There is the facility to connect a Fan Switch.

A fan switch (Merlin FS1 or FS2 - sold separately) provides the facility to turn on fan(s) when the 1000S+i panel is switched on and removes power to fan(s) when the switched off.

There is a switch located on the circuit board labelled [EM SEL].

OFF	Instructs the system to shut down fan(s) and gas supply upon activation of emergency shut off button(s). (Default)
ON	Instructs the system to leave the fans on and shut off the gas supply only upon activation of emergency shut off button(s).



Note: This option is not available if a Fan Switch is not installed.

Fire Panel Integration

The Merlin 1000S+i can be integrated with a fire alarm to close the gas supply automatically in the event of a fire. The volt free fire alarm signal can be wired in series with any remote emergency shut off buttons.

If there are no remote emergency shut off buttons being installed, wire this directly to the terminal marked [EM REMOTE].

Auto Shut-Down - Timeout Period

The system has an auto-shut down feature after a selected time. There are two switches located on the circuit board labelled [TIME1] & [TIME2].

These can be configured to select the required timeout/ shut-down period.



TIME 1	TIME 2	Timeout Period
OFF	OFF	2 Hours (Default)
ON	OFF	4 Hours
OFF	ON	8 Hours
ON	ON	Disabled

Note: Upon timeout the gas supply will be turned off unless other utilities are configured.

Auto Shut-Down – Selectable Utility

There is a switch located on the circuit board labelled [ELECTR].

It is factory set to 'Off'.

On installation, it can be switched 'On' - this will instruct the system to also turn off Electric services when performing auto-shut down/ timeout.



Specification

Model:	1000S+i
Visual Indication	LED
Mains Electrical Power Input	100-120VAC
Gas Solenoid Valve Output	100-120VAC
Electrical Contactor Output	100-120V AC
Current Consumption	12W max (50mA) @ 120VAC
Internal Fuse	3.15A
Operating Temperature	32 – 104°F 0-95%RH Non-Condensing
Audible Alarm Buzzer dB	65 dB (300mm distance in quiet conditions)
Internet connection	N/A
Housing Material	Polylac PA-765
Flame Rating	UL 94
Approvals	CE, RoHS
O/All Dimensions (H x W x D) mm / inch	7.08 x 10 x 3.03"

OPERATION

First Power Up

On connecting mains power, an LED on the front of the panel (AGS Logo) will illuminate red.

1. Turn the key switch to on position.
2. Gas, electric & water will flash for 10 seconds.
3. Press relevant service button to turn required utility on.
Turn the key switch to the off position to turn the panel off.

Note: All services can be turned on or off within 10 seconds only of the key switch being turned on. After 10 seconds, all utility buttons will be disabled.

The user must turn the key off and back on to adjust any services.

Emergency Shut Off Button

The emergency shut off button is located on the front of the panel.

There is also a facility for remote shut off buttons to be wired in series on the circuit board.

The emergency shut off button(s) will cut off the gas supply and electrics only when activated. To reinstate the system, the emergency shut off button(s) will need to be reset and the panel restarted.

LED Indicators

Gas

When the key switch is turned on, the system will check the installation for gas leaks.

If gas proving is successful, the LED will illuminate.

ON = Gas On

OFF = Gas Off

Electric

When Electric service is turned on, the Electric LED will illuminate.

ON = Electric On

FLASHING = Electric Off, Electric button enabled

OFF = Electric Off, Electric button disabled.

Testing

Under normal working conditions this LED is off.

This feature is disabled.

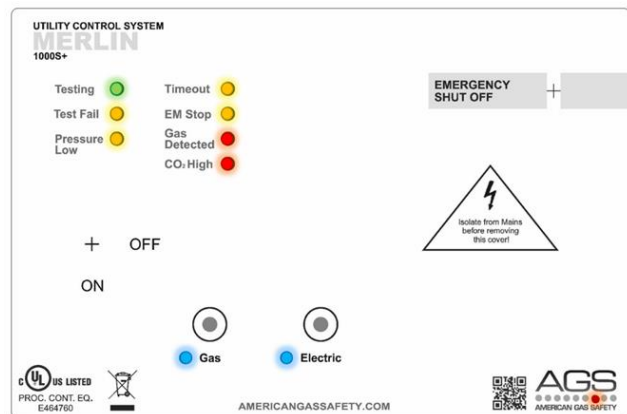

- **Test Fail**

Under normal working conditions this LED is off.
This feature is disabled.

- **Pressure Low**

Under normal working conditions this LED is off.
This feature is disabled.

- **Timeout**

Under normal working conditions this LED is off.
This LED will illuminate AMBER when auto-shut down has occurred.

OFF = OK

ON = Auto-shut down activated

- **EM Stop**

If an emergency shut off button (either remote or on the panel) is pressed, the LED will illuminate AMBER and the gas will be turned off.

The EM Stop button must be reset before restarting the system.

OFF = OK

ON = Emergency Shut-Off button activated.

- **Gas Detected**

Under normal working conditions this LED is off.

If the external Merlin detector connected detects gas this will show RED and the gas valve will turn off.

OFF = OK

ON = Gas detected.

- **CO₂ High**

Under normal working conditions this LED is off.

If the concentration of CO₂ in the air is at alarm level (relevant detector required), the LED will show RED and the Gas valve will turn off.

OFF = OK

ON = the concentration of CO₂ is at alarm level.

Servicing & General Maintenance



It is recommended that any detectors connected to the system are inspected and serviced at least annually from the date of installation for optimum performance and protection.

- ✓ DO carefully remove any accumulated dust from the outer enclosure once a month.
- ✗ NEVER use detergents or solvents to clean your device – this may permanently or temporarily damage the gas sensing elements.
- ✗ NEVER spray lighter gas, paint or other aerosols near detectors or monitors.
- ✗ NEVER paint devices. Paint will seal vents and may interfere with devices.



Avoid exposure of high concentrations of alcohol found in many products, this can damage, deteriorate or affect gas detectors. For more information refer to your detector manual.

Bump Testing

What is bump testing?

'Bump testing' is a term used for checking a gas detector is functioning correctly by exposing it to the target gas. A known concentration of the target gas is applied to the sensor to trigger an alarm condition and ascertain the detector is working safely.

Why is it important?

A detector may visually appear in good order, but its sensitivity can be inhibited by external factors. Dust, humidity, temperature fluctuations, cleaning products, contaminants or sensor drift (ageing) can cause a decline in sensitivity and eventual failure. Regular 'bump tests' are important to make sure the detector is able to detect a release of gas as early as possible.

How often?

A 'bump test' takes seconds and is often completed alongside a scheduled fire alarm test. We recommend this is done at least weekly to reduce the risk of a detector not performing, however the frequency should be determined from a risk assessment by the end user.

Please remember, 'bump testing' does not remove the need to have gas detectors inspected, calibrated and serviced periodically by a trained engineer.

For more help and advice on bump testing, calibration and service – contact us.



IMPORTANT WARNING STATEMENTS

Please take the time to thoroughly read this user's guide which should be retained for future reference.

It is recommended that this device be commissioned upon installation.

Do not apply lighter gas or other aerosols to detectors – this will cause extreme damage to the gas sensing elements.

High concentrations of alcohol found in many products may damage, deteriorate or affect the gas sensing elements of the detectors – Avoid exposure near your devices.

Never ignore your devices when in alarm. Actuation of your alarm indicates the presence of an error or issue that requires immediate attention.

This device requires a continual supply of electrical power – it will not work without power.

This device should not be used to substitute proper installation, use and/or maintenance of fuel burning appliances including appropriate ventilation and exhaust systems.

Your product should reach you in perfect condition, if you suspect it is damaged, contact your supplier.

Manufacturer's Warranty

3 Year Manufacturer's Warranty

Warranty coverage:

The manufacturer warrants to the original consumer purchaser, that this product will be free of defects in material and workmanship for a period of three (3) years from date of purchase. The manufacturer's liability hereunder is limited to replacement of the product with repaired product at the discretion of the manufacture. This warranty is void if the product has been damaged by accident, unreasonable use, neglect, tampering or other causes not arising from defects in material or workmanship. This warranty extends to the original consumer purchaser of the product only.

Warranty disclaimers:

Any implied warranties arising out of this sale, including but not limited to the implied warranties of description, merchantability and intended operational purpose, are limited in duration to the above warranty period. In no event shall the manufacturer be liable for loss of use of this product or for any indirect, special, incidental or consequential damages, or costs, or expenses incurred by the consumer or any other user of this product, whether due to a breach of contract, negligence, strict liability in tort or otherwise. The manufacturer shall have no liability for any personal injury, property damage or any special, incidental, contingent or consequential damage of any kind resulting from gas leakage, fire or explosion. This warranty does not affect your statutory rights.

Warranty Performance:

During the above warranty period, your product will be replaced with a comparable product if the defective product is returned together with proof of purchase date. The replacement product will be in warranty for the remainder of the original warranty period or for six months – whichever is the greatest.



Information on waste disposal for consumers of electrical & electronic equipment.

When this product has reached the end of its life it must be treated as Waste Electrical & Electronics Equipment (WEEE). Any WEEE marked products must not be mixed with general household waste, but kept separate for the treatment, recovery and recycling of the materials used. Please contact your supplier or local authority for details of recycling schemes in your area.

Notes

Notes

Installation Details

Please pass this manual to the system owner or system user.

Date of Installation:	
Installation Location:	
Organisation:	
Stamp/ Signature of the installer:	

CONTACT US:

AGS Head Office

Tel: (727) 608-4375

Fax: (727) 538-4237

info@americangassafety.com



American Gas Safety is the owner of this document and reserves all rights of modification without prior notice.