

# AGS

AMERICAN GAS SAFETY

UL US LISTED

## AGSENCSS Datasheet

### Stainless Steel Solenoid Valve Enclosures



#### Product Overview

Designed for general purpose indoor commercial use to enclose mechanical valves such as solenoid valves & ball valves. The hinged cover with latch provides easy access during installation and maintenance.

#### Standards



#### Construction

- ✓ Continuous seam welded 16 gauge steel or stainless steel construction
- ✓ Hinged cover clamps to the base with keyed quarter turn latch for a watertight seal
- ✓ External mounting brackets allow box to be mounted on a wall or panel without having to remove the cover and exposing internal components to the environment
- ✓ Bonding studs for grounding are provided on base and door
- ✓ Internal panel and hardware included
- ✓ Easily machined and modified to your particular requirements
- ✓ Rigid door design
- ✓ Continuous gasket
- ✓ Bar folded flange to enhance seal performance
- ✓ Additional rubber washer inside mounting brackets to enhance water resistant seal
- ✓ Added locks in larger size enclosures

#### Finish

- ✓ Smooth gray powder coat, Internal Panel - Clear Zinc plate

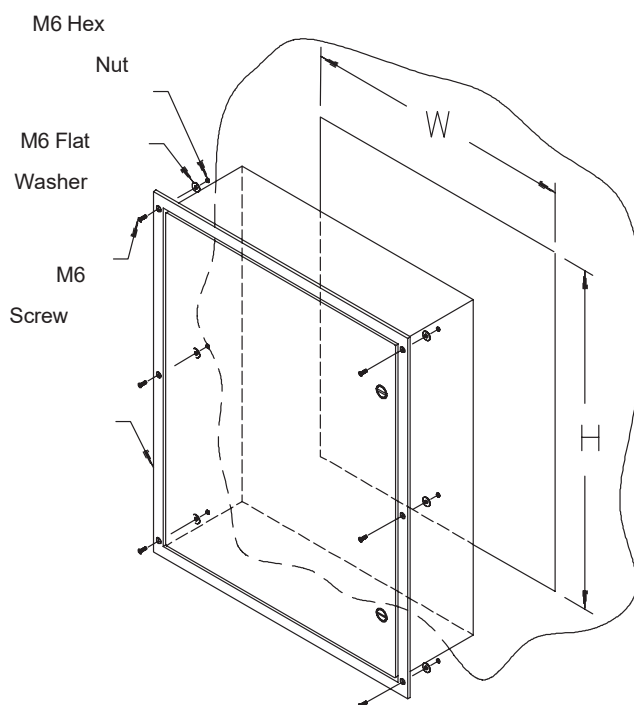



## Sizes Available

Part Code	Height ± .25 (inches)	Width ± .25 (inches)	Depth ± .25 (inches)
AGSENC866SS	8	6	6
AGSENC884SS	8	8	4
AGSENC1084SS	10	8	4
AGSENC1086SS	10	8	6
AGSENC12106SS	12	10	6
AGSENC12108SS	12	10	8
AGSENC12126SS	12	12	6
AGSENC12128SS	12	12	8
AGSENC16126SS	16	12	6
AGSENC16128SS	16	12	8
AGSENC16128SS	16	12	8
AGSENC16148SS	16	14	8
AGSENC16168SS	16	16	8
AGSENC20168SS	20	16	8
AGSENC202012SS	20	20	12
AGSENC24168SS	24	16	8
AGSENC24208SS	24	20	8
AGSENC242410SS	24	24	10

Find out more

**American Gas Safety LLC**

[www.americangassafety.com](http://www.americangassafety.com)

Head office:

6304 Benjamin Road, Suite 502, Tampa, FL 33634

Tel: (727) 608-4375

Email: [info@americangassafety.com](mailto:info@americangassafety.com)

