



## Key Features

- Automatic control over the gas supply
- Clear LED status display
- Gas pressure drop test and continuous supply pressure check via pressure transducer
- Built-in connectivity to existing BAS and fire alarms
- Additional external gas detection sensors available
- Key lock for authorization control
- Panel mounted panic button

## Overview

The Merlin 1000S utility control panel gives the user complete control over the gas within the room. Utilizing a solenoid valve and a pressure transducer the Merlin 1000S will check for a pressure drop or leak in the downstream gas line before allowing the gas to be supplied. Once gas has been supplied, the unit will constantly check the incoming gas supply pressure to ensure that a naked flame cannot be extinguished by a weak draft. The key lock ensures that only authorized personnel can operate the utilities. The emergency panic button is shrouded to ensure no accidental shutdowns occur.

All the Merlin utility controls come with clearly labelled PCB boards to ensure easy installation. Additional gas detection sensors can be wired to the unit for extra safety. Built-in connectivity to existing BAS systems and inputs for existing fire alarms make the unit perfect for renovation projects as well as new build. Dip switches on the reverse side of the fascia panel allow for onsite adjustments of various parameters including, the gas fill and prove time, how the unit communicates with the BAS system and the time-out function.

## Application

- K-12 and Higher Ed Science Classrooms.
- Designed to meet NSTA guidelines.
- Isolation of the gas supply in the event of high Fuel Gas or CO2 concentrations.
- Fire Houses
- Decorative gas powered fire pits.
- Gas BBQ's installations.
- Commercial industrial spaces.
- Automatic isolation of the gas supply upon EM stop or gas detection.

## Technical Specifications

Power Supply	110-120vac, 50/60HZ
Protection	Overvoltage, overcurrent, surge protection (3amp)
Enclosure	Wall mounted Fully UL certified enclosure. Flush Mount kit available.
Dimensions	W: 10 1/16" x H: 7 1/16" x D: 3 1/16"
Utility 1 Control Signal Output	110-120vac, 50/60HZ
BAS Output	N/C COM N/O - Max 1A @ 120vac
EM Stop Input	Volt Free*
Fan Switch Output	Volt Free*
Sensor Power Output	24VDC
Sensor Signal Input	Volt Free
Gas Pressure Transducer Power Output	12VDC
Gas Pressure Transducer Signal Input	0-5VDC
CO <sup>2</sup> Monitor Signal Input	Volt Free*
Adjustable Time-out period	2 hour, 4 hour, 8 hour or disabled
Adjustable BAS Signal Output	Alarm "on" or Gas "on" / Gas "off"
Adjustable Gas Fill Time	5 seconds or 10 seconds
Adjustable Prove Time	30 seconds or 60 seconds

## Merlin 1000S Wiring Example

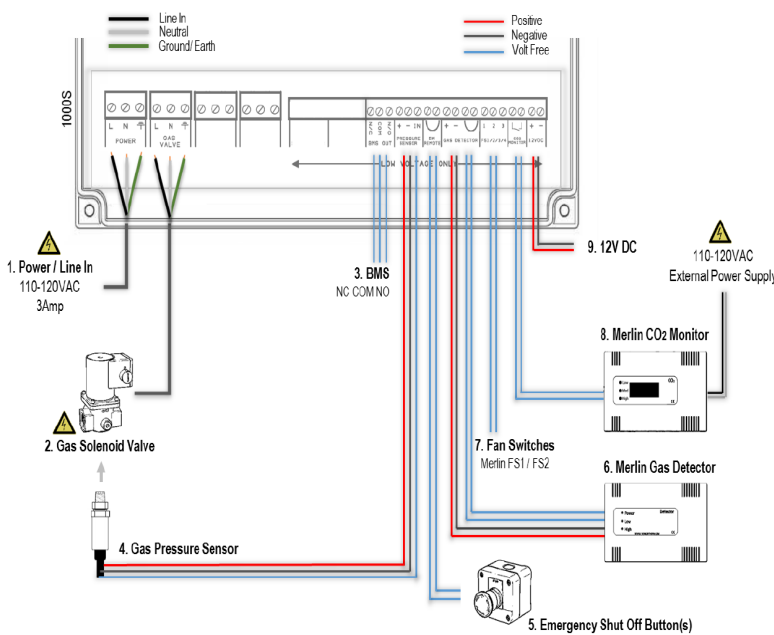

## Gas Proving Transducer Overview

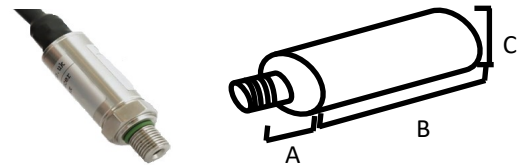

The AGS Merlin pressure transmitter is used with the AGS range of gas proving systems. This pressure transmitter checks the gas pipe work for leaks every time the system is turned on.

In the event of a gas leak or a open appliance during the testing sequence, the transmitter will send a signal to the Merlin unit to isolate the gas valve.

### Dimensions

A = 3/8"

B = 1"

C = 7/8"

The transmitter comes with approximately 3ft of prewired cable.