

Gas Safety Products

Merlin 1500S Gas Interlock System



Installation, operating and maintenance



Table of contents

1	General information.....	3
2	Installation.....	3
2.1	Panel Mounting.	3
2.2	Mains Supply.	3
2.3	Gas solenoid valve.	3
2.4	Supply Fan & Extract Fan PD Switches.	3
2.5	BMS Connections.	3
2.6	Remote emergency shut off buttons.	3
2.7	Gas Detector.	3
2.8	FS 123.	3
2.9	CO2 Monitor.....	3
2.10	12v DC.....	3
2.11	Internal Buzzer.	3
3	Operation Instructions.....	4
3.1	How to turn the system on and off	4
3.2	Explanation of LED status.....	4
3.2.1	Power LED	4
3.2.2	Gas on LED	4
3.2.3	Supply fans LED	4
3.2.4	Extract fans LED	4
3.2.5	Fan Fault LED	4
3.2.6	EM Stop LED.....	5
3.2.7	Gas Detected LED	5
3.2.8	CO2 High LED.....	5
3.3	CO ₂ MODE.....	5
3.4	Using the emergency shut off.....	5
3.5	BMS integration.....	6
3.6	Fire alarm integration	6
3.7	Fan switch integration	6
	1500S Wiring Diagram	7

1 General Information

The Merlin 1500S is a ventilation interlock panel.

The Merlin 1500S can receive connections from up to four external remote air pressure differential switches or current monitors, remote emergency shut-off buttons, gas detectors and a Merlin CO₂ monitor. It can also be integrated with a BMS and fire alarm.

It is recommended that the user reads this guide before using the system. Please do NOT attempt to operate the unit until the contents of this document have been read and are thoroughly understood.

2 Installation

2.1 Panel Mounting. The control panel is designed for surface mounting using 4 mounting screws. Removing the cover on the panel gives access to the circuit board. The PCB should be removed before drilling entry holes into the case.

2.2 Mains Supply. A 110-120VAC electrical supply should be supplied to the panel. This should be externally fused at 3 Amps using a fused spur and should be connected to the terminals marked [LNE Power].

2.3 Gas solenoid valve. The gas solenoid valve should be powered using the terminals on the Merlin 1500S marked [LNE GAS VALVE].

2.4 Supply Fan & Extract Fan PD Switches These terminals are used to receive an input signal from external air pressure switches or external current monitors. These are linked out as a factory setting. Wiring should be made using two-core volt free connections. If only one fan is being used the terminals not in use should be left linked out.

2.5 BMS Connections Terminal connections are available on the circuit board for connections to Building Management systems etc. Detailed on the circuit board as [BMS OUT N/C, Com and N/O] these are volt free connections.

2.6 Remote emergency shut off buttons. The terminal for remote emergency shut-off buttons is detailed on the circuit board as [EM REMOTE]. These connections are linked out as a factory setting. Remote emergency shut-off buttons should be volt free and wired to the Merlin 1500S using two-core cable.

2.7 Gas Detector The terminals detailed on the circuit board as "Gas Detector". These connections are [+ - .

2.8 FS 123 This terminal switches when the key is turned on and off. This can be linked to a fan switch (panel supplied separately) which can provide power to the fans when the control panel is switched on.

2.9 CO₂ Monitor This terminal can be wired to CO₂ monitor to shut off the system in the event of CO₂ being at alarm level. If no CO₂ monitor is supplied leave the terminal link in.

2.10 12v DC This is a permanent 12v DC output when there is power at the panel. This is normally used to power a PM₂ current monitor. (Supplied separately)

2.11 Internal Buzzer Operates at 65dB measured 30cm from closed panel.

Note: all low voltage connections should be made using a screened cable. To avoid electrical interference this should not be in the same conduit as mains cable as per the low voltage directive.

3 Operation Instructions

3.1 How to turn the system on and off

1. Turn the Fans On.
2. Turn the key switch to on position.
3. To turn the system off, turn the key switch to off position.

3.2 Explanation of LED status

Power LED

When the system is connected to the mains supply, the Red LED of the AGS Logo located in the bottom right corner of the panel will illuminate. When no power is present, this LED will not light up.

RED = OK

OFF = No power to 1500S, a loose ribbon connection or the fuse may not be intact.

Gas On LED

When the fans are running at the correct speed and the key switch is turned on, the Merlin 1500S will open the gas valve and the green 'Gas On' LED will illuminate.

GREEN = Gas On

OFF = Gas Off

Supply Fans LED

Under normal working the LED will illuminate GREEN. If a supply fan fault is detected, the LED will be flashing.

GREEN = OK

FLASHING = One of the supply fans is not running.

Extract Fans LED

Under normal working the LED will illuminate GREEN. If an extract fan fault is detected, the LED will be flashing.

GREEN = OK

FLASHING = One of the extract fans is not running

IF SUPPLY AND/OR EXTRACT FANS LED FLASHES FOR MORE THAN 20 SECONDS, THE Merlin 1500S WILL SHUT OFF THE GAS.

Fan Fault LED

Under normal working conditions this LED is off. If a fan fault is present for more than 20 seconds, the LED will illuminate RED.

OFF = OK

RED = the gas supply has been shut off due to a ventilation fault.

**IF A FAULT IS FOUND YOU WILL NEED TO CONTACT YOUR SERVICE/MAINTENANCE COMPANY
YOU SHOULD NOT ATTEMPT TO CARRY OUT A REPAIR UNLESS YOU ARE QUALIFIED TO DO SO.**

EM Stop LED

If an emergency shut off button (either remote or on the panel) is pressed, the LED will illuminate AMBER and the gas will be turned off. The EM Stop button must be re-set before restarting the system.

OFF = OK

AMBER = EM Stop button pressed

Gas Detected LED

Under normal working conditions this LED is off. If the external Merlin detector connected detects gas this will show RED and the Gas valve will turn off.

OFF = OK

RED = Gas detected.

CO2 High LED

Under normal working conditions this LED is off. If the concentration of CO₂ in the air is at alarm level (relevant detector required), the LED will show RED and the Gas valve will turn off.

OFF = OK

RED = the concentration of CO₂ is at alarm level.

3.3 CO₂ Mode

Under normal working conditions the Merlin 1500S monitors the ventilation and the concentration level of CO₂. In the event of ventilation failure or if the CO₂ level is at alarm level, the panel will shut off the gas supply.

The Merlin 1500S features a 'CO₂ Mode' this allows the kitchen to have the access to the gas supply in the event of a fan failure. There is a 'CO₂ Mode' button located on the front of the panel. This button will only be available to use when 'Fan fault' LED illuminates Red. To enable the CO₂ Mode, the 'CO₂ button' has to be pressed for 5 seconds. The Fan Fault LED will go off and CO₂ Mode LED will come on. In this mode, the Merlin 1500S will monitor only the CO₂ levels to ensure there is a safe working environment. This mode will allow the gas valve to open for 8 hours each time the system is energised, provided there are satisfactory levels of CO₂.

At the end of 8 hours, the gas valve will close and CO₂ Mode LED will be flashing.

To reinstate the system the panel has to be restarted. The 'CO₂ Mode' will be permanently disabled if a CO₂ Sensor is not detected at power up.

3.4 Using the Emergency Shut Off

The Emergency shut off button is located on the front of the panel. There is also a facility for remote shut off buttons to be wired in series.

The Emergency shut off button(s) will cut off the gas supply when activated.

To reinstate the system, the Emergency shut off button(s) will need to be reset and the panel restarted.

3.5 BMS integration

The Merlin 1500S can be integrated with a BMS to make or break a circuit on gas on/gas off, (valve open or valve closed). This will tell the BMS whether or not 100-240VAC is being sent to the solenoid.

There is a dip-switch located on the inside facia of the Merlin 1500S labelled 'BMS Selection'. This is factory set in the 'off' position which signals the BMS on gas on/gas off. When switched to the 'on' position, the 1500S will only signal the BMS on a gas detected.

3.6 Fire alarm integration

The Merlin 1500S can be integrated with a fire alarm to close the gas supply automatically in the event of a fire.

The volt free fire alarm signal can be wired in series with any remote emergency shut off buttons. If there is no remote emergency stop buttons installed wire this directly to the terminal marked 'EM REMOTE'.

3.7 Fan Switch Integration

There is the facility to connect a Fan Switch (FS1 or FS2 sold separately).

The Fan Switch provides the facility to turn on the fan(s) when the key switch on the Merlin 1500S is in the on position and turn the power off to the fan(s) when the key switch on the Merlin 1500S is in the off position.

There is a dip-switch located inside the facia of the Merlin 1500S labelled EM Selection.

This is factory set in the 'off' position which instructs the system to shut down the fan(s) and gas supply on activation of the Emergency shut off button(s). On installation, this can be switched to the 'on' position if required. This will instruct the system to leave the fans on and only shut off the gas supply on activation of the Emergency shut off button(s). Note: This option is not available if Fan Switch is not installed.

1500S Wiring Diagram

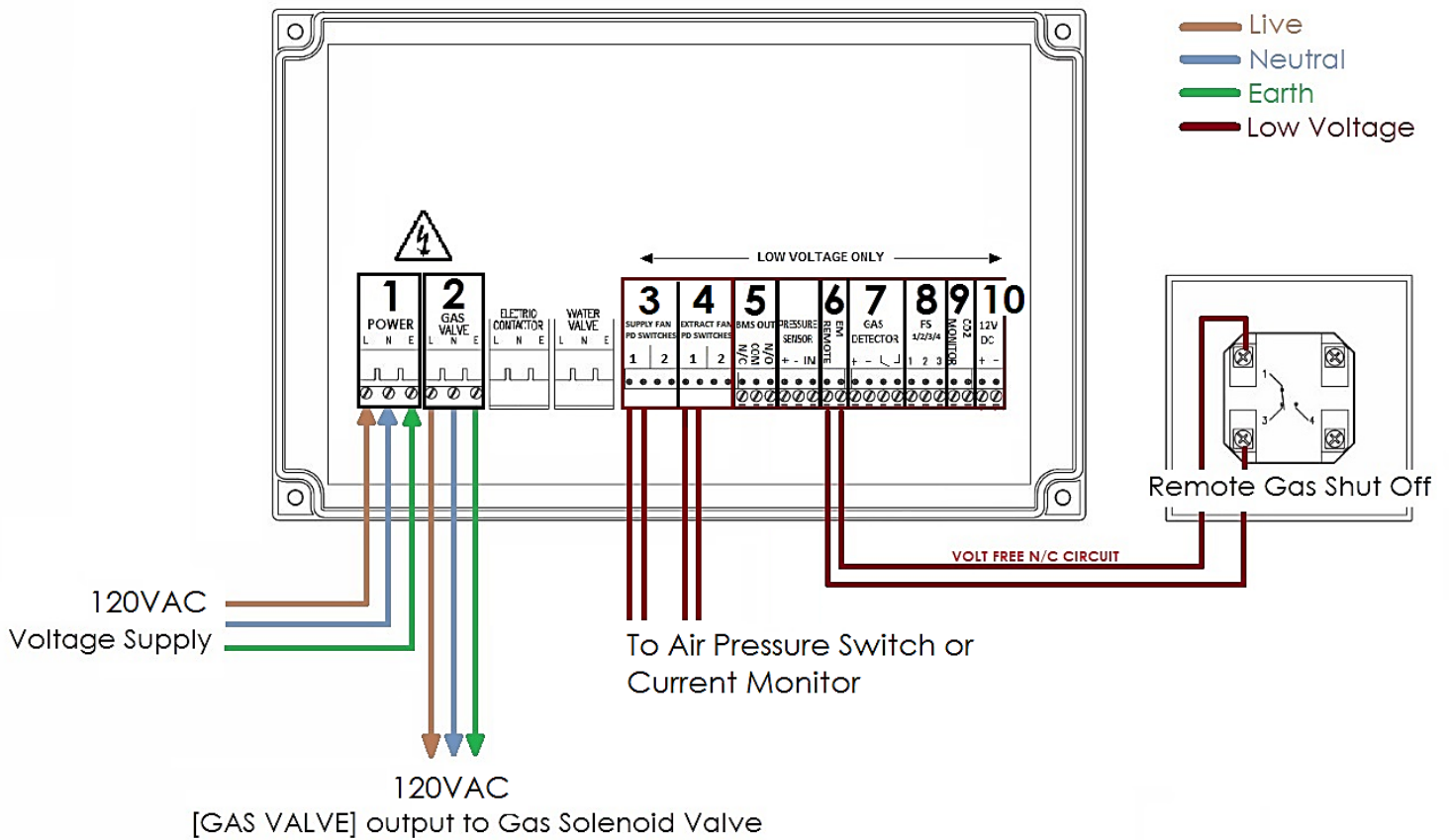

1. Mains Input 110-120VAC.
2. Gas Solenoid Valve Power Output, 110-120VAC.
3. Supply Fan 1 and 2 external pressure differential switch or current switch. **VOLT FREE INPUT**
4. Extract Fan 1 and 2 external pressure differential switch or current switch. **VOLT FREE INPUT**
5. BMS output contacts. Normally Closed, Common and Normally Open. Max.1A @ 120VAC.
6. Remote EM Stop buttons and Fire Alarm input wired in series (purchased separately). **VOLT FREE INPUT**
7. Methane, CO or LPG Detector, power supply and **VOLT FREE INPUT** (purchased separately).
8. Fan Switch output (purchased separately). For wiring instruction see Fan Switch user manual.
9. CO2 Monitor (purchased separately). **VOLT FREE INPUT**
10. Permanent 12VDC output (Normally used to power a PM2 Current Monitor). **50A Max.**

Please note, Mains wires and low voltage wires should not be run in the same conduit as per the **LOW VOLTAGE DIRECTIVE**



INFORMATION ON WASTE DISPOSAL FOR CONSUMERS OF ELECTRICAL & ELECTRONIC EQUIPMENT

When this product has reached the end of its life it must be treated as Waste Electrical & Electronics Equipment (WEEE). Any WEEE marked products must not be mixed with general household waste, but kept separate for the treatment, recovery and recycling of the materials used. Please contact your supplier or local authority for details of recycling schemes in your area.

CONTACT US:

AGS Head Office

Tel: (727) 608-4375

Fax: (727) 538-4237

info@americangassafety.com



American Gas Safety is the owner of this document and reserves all rights of modification without prior notice.