



# Gas Safety Products

## Merlin 1500S

Gas & Ventilation interlock system



## User Guide



Please read this guide carefully and retain for future use.

---

## Table of contents

<b>1</b>	<b>General Information.....</b>	<b>3</b>
1.1	Panel Mounting.....	3
<b>2</b>	<b>Circuit Board Terminals.....</b>	<b>4</b>
2.1	LINE VOLTAGE.....	4
2.2	VALVE OUT.....	4
2.3	SUPPLY FAN & EXTRACT FAN PD SWITCHES.....	4
2.4	BMS OUT.....	4
2.5	EM REMOTE.....	4
2.6	GAS DETECTOR.....	5
2.7	FS 1/2/3/4.....	5
2.8	CO2 Monitor.....	5
2.9	12V DC.....	5
<b>3</b>	<b>Installation &amp; Operation.....</b>	<b>6</b>
3.1	System ON and OFF.....	6
3.2	Emergency Shut Off.....	6
3.3	BMS integration.....	6
3.4	Fan Switch Integration.....	6
3.5	Fire alarm integration.....	7
3.6	CO <sub>2</sub> Mode (Select Models Only).....	7
<b>4</b>	<b>Panel LED status.....</b>	<b>8</b>
<b>5</b>	<b>1500S Wiring Spec.....</b>	<b>10</b>
<b>6</b>	<b>Manufacturer's Warranty.....</b>	<b>12</b>

# 1 General Information

The Merlin 1500S is a ventilation interlock panel.

The Merlin 1500S can receive connections from up to four external remote air pressure differential switches or current monitors, remote emergency shut-off buttons, gas detectors and a Merlin CO<sub>2</sub> monitor. It can also be integrated with a BMS and fire alarm.

It is recommended that the user reads this guide before using the system. Please do NOT attempt to operate the unit until the contents of this document have been read and are thoroughly understood.

## 1.1 Panel Mounting.

The control panel is designed for surface mounting using 4 mounting screws. Removing the cover on the panel gives access to the circuit board.

The PCB should be removed before drilling entry holes into the case. A flush mount kit is available, comprising of a mounting bracket and decorative surround strip. Contact your supplier for more information.



## Important Warning Statements

Never ignore your device when in alarm.

This device requires a continual supply of electrical power – it will not work without power.

This device should not be used to substitute proper installation, use and/or maintenance of fuel burning appliances including appropriate ventilation and exhaust systems.

Your product should reach you in perfect condition, if you suspect it is damaged, contact your supplier.



### Information on waste disposal for consumers of electrical & electronic equipment. (EEE)

When this product has reached the end of its life it must be treated as Waste Electrical & Electronics Equipment (WEEE). Any WEEE marked products must not be mixed with general household waste, but kept separate for the treatment, recovery and recycling of the materials used.

Please contact your supplier or local authority for details of recycling schemes in your area.

## 2 Circuit Board Terminals

### 2.1 LINE VOLTAGE

A 110-120VAC electrical supply should be externally fused at 3A and connected to the terminals marked [LINE VOLTAGE LNE].

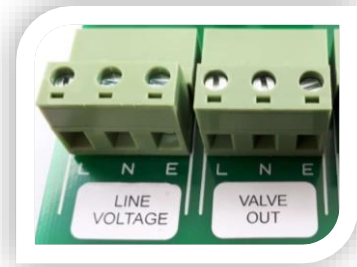

### 2.2 VALVE OUT

The 110-120VAC gas solenoid valve should be powered using the terminals on the Merlin 1000S detailed [VALVE OUT LNE].

### 2.3 SUPPLY FAN & EXTRACT FAN PD SWITCHES

These terminals are used to receive an input signal from external air pressure switches or external current monitors. These are linked out as a factory setting as shown.

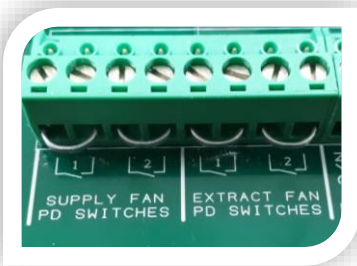

Wiring to switches & current monitors should be made using two-core volt free connections.

If only one fan is being used the terminals not in use should be left linked out.

### 2.4 BMS OUT

Terminal connections are available on the circuit board for connections to Building Management systems.

This is a relay that changes state in alarm or when gas is on/off and can be used in conjunction with the [12VDC] output and other external relays that affect other devices and controls such as purge fans, audible alarms etc.

Detailed on the circuit board as [BMS OUT] normally closed (N/C), common (COM) and normally open (N/O). These are volt free connections.

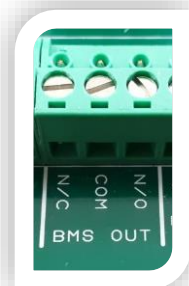

### 2.5 EM REMOTE

The terminal for remote emergency shut-off buttons is detailed on the circuit board as [EM REMOTE].

These connections are linked out as a factory setting.

Remote emergency shut-off buttons should be volt free and wired to the Merlin 1500S using a plenum security cable, white, 18/2 (18AWG 2 conductor), stranded, CMP or similar.



### 2.6 GAS DETECTOR

These connections can be wired to a Merlin gas detector (LPG, natural gas or carbon monoxide) as shown.

If no detector is being used leave the link in between the "L J".

Refer to your detector guide for more information.

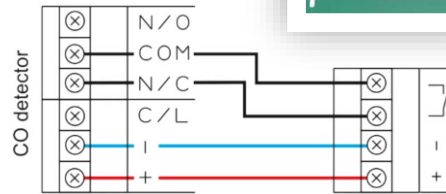

### 2.7 FS 1/2/3/4

This terminal switches when the key is turned on and off.

This can be linked to a fan switch (panel supplied separately) which can provide power to the fans when the control panel is switched on.

### 2.8 CO2 Monitor

This terminal can be wired to CO2 monitor to shut off the system in the event of CO2 being at alarm level.

If no CO2 monitor is connected, the panel will 'beep' and CO2 LED will flash 3 times to indicate this terminal has been disabled.

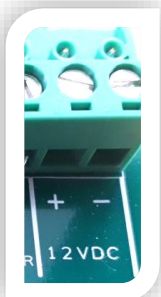
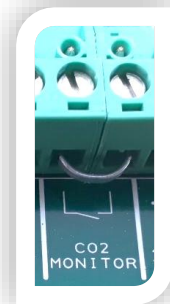

### 2.9 12V DC

This is a permanent 12v DC output when there is power at the panel and can be used to create a relay switch with the BMS relay output.

This is normally used to power a PM2 current monitor. (Supplied separately) Contact your supplier for more information.

## 3 Installation & Operation

### 3.1 System ON and OFF

- Turn the Fans On.
- Turn the key switch to ON position.
- To turn the system off, turn the key switch to OFF position.

### 3.2 Emergency Shut Off

The emergency shut off button is located on the front of the panel.

There is also a facility for remote shut off buttons to be wired in series on the circuit board.

The emergency shut off button(s) will cut off the gas supply when activated.

To reinstate the system, the emergency shut off button(s) will need to be reset and the panel restarted.

### 3.3 BMS integration

The Merlin 1500S can be integrated with a BMS to make or break a circuit on gas on/gas off, (valve open or valve closed). This will tell the BMS whether or not 110-120VAC is being sent to the solenoid.

There is a dip-switch located on the inside facia of the Merlin 1500S labelled [BMS SEL].

This is factory set in the OFF position which signals the BMS on gas on/gas off.

When switched to the ON position, the 1500S will only signal the BMS on a fault, i.e. fan fault, CO2 high level detected, gas detected, EM Stop pressed, etc.

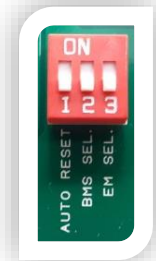

### 3.4 Fan Switch Integration

There is the facility to connect a Fan Switch (FS1 or FS2 sold separately).

The Fan Switch provides the facility to turn on the fan(s) when the key switch on the Merlin 1500S is in the on position and turn the power off to the fan(s) when the key switch on the Merlin 1500S is in the off position.

There is a dip-switch located inside the facia of the Merlin 1500S labelled [EM SEL].

This is factory set in the OFF position which instructs the system to shut down the fan(s) and gas supply on activation of the Emergency shut off button(s).

On installation, this can be switched to the ON position if required. This will instruct the system to leave the fans on and only shut off the gas supply on activation of the Emergency shut off button(s).

Note: This option is not available if Fan Switch is not installed.

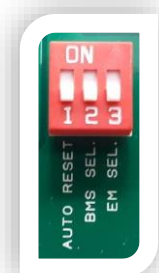

### 3.5 Fire alarm integration

The Merlin 1500S can be integrated with a fire alarm to close the gas supply automatically in the event of a fire.

The volt free fire alarm signal can be wired in series with any remote emergency shut off buttons.

### 3.6 CO<sub>2</sub> Mode (Select Models Only)

Under normal working conditions the Merlin 1500S monitors the ventilation and the concentration level of CO<sub>2</sub>. In the event of ventilation failure or if the CO<sub>2</sub> level is at alarm level, the panel will shut off the gas supply.

The Merlin 1500S features a 'CO<sub>2</sub> Mode' this allows the kitchen to have the access to the gas supply in the event of a fan failure. There is a 'CO<sub>2</sub> Mode' button located on the front of the panel. This button will only be available to use when 'Fan fault' LED illuminates Red. To enable the CO<sub>2</sub> Mode, the 'CO<sub>2</sub> button' has to be pressed for 5 seconds. The Fan Fault LED will go off and CO<sub>2</sub> Mode LED will come on. In this mode, the Merlin 1500S will monitor only the CO<sub>2</sub> levels to ensure there is a safe working environment. This mode will allow the gas valve to open for 8 hours each time the system is energised, provided there are satisfactory levels of CO<sub>2</sub>.

At the end of 8 hours, the gas valve will close and CO<sub>2</sub> Mode LED will be flashing.

To reinstate the system the panel has to be restarted. The 'CO<sub>2</sub> Mode' will be permanently disabled if a CO<sub>2</sub> Sensor is not detected at power up.

## 4 Panel LED status

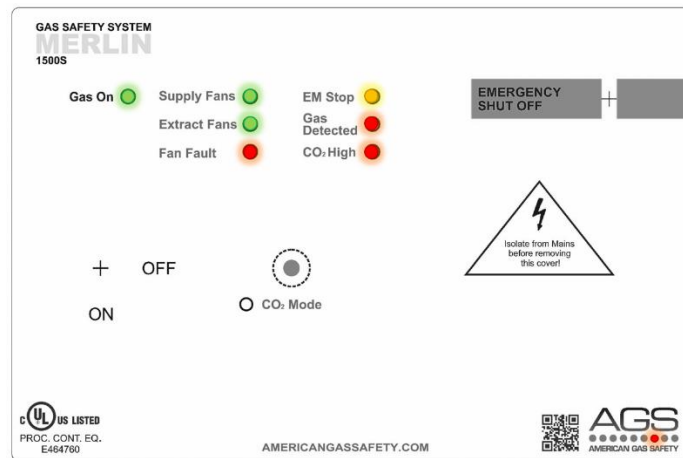

When the system is connected to the mains supply, the Red LED of the AGS Logo located in the bottom right corner of the panel will illuminate.

When no power is present, this LED will not light up.

### ● Gas On

When the fans are running at the correct speed and the key switch is turned on, the Merlin 1500S will open the gas valve and the green 'Gas On' LED will illuminate.

ON = Gas On

OFF = Gas Off

### ● Supply Fans

Under normal working the LED will illuminate GREEN. If a supply fan fault is detected, the LED will be flashing.

ON = OK

FLASHING = One of the supply fans is not running.

### ● Extract Fans

Under normal working the LED will illuminate GREEN. If an extract fan fault is detected, the LED will be flashing.

ON = OK

FLASHING = One of the extract fans is not running

**IF SUPPLY AND/OR EXTRACT FANS LED FLASHES FOR MORE THAN 20 SECONDS, THE GAS WILL SHUT OFF.**



- **Fan Fault**

Under normal working conditions this LED is off. If a fan fault is present for more than 20 seconds, the LED will illuminate RED.

OFF = OK

ON = the gas supply has been shut off due to a ventilation fault.

IF A FAULT IS FOUND YOU WILL NEED TO CONTACT YOUR SERVICE/MAINTENANCE COMPANY.  
YOU SHOULD NOT ATTEMPT TO CARRY OUT A REPAIR UNLESS YOU ARE QUALIFIED TO DO SO.

- **EM Stop**

If an emergency shut off button (either remote or on the panel) is pressed, the LED will illuminate AMBER and the gas turned off. The EM Stop button must be re-set before restarting the system.

OFF = OK

ON = EM Stop button pressed

- **Gas Detected**

Under normal working conditions this LED is off. If the external Merlin detector connected detects gas this will show RED and the Gas valve will turn off.

OFF = OK

ON = Gas detected.

- **CO<sub>2</sub> High**

Under normal working conditions this LED is off. If the concentration of CO<sub>2</sub> in the air is at alarm level (relevant detector required), the LED will show RED and the Gas valve will turn off.

OFF = OK

ON = the concentration of CO<sub>2</sub> is at alarm level.

## 5 1500S Wiring Spec

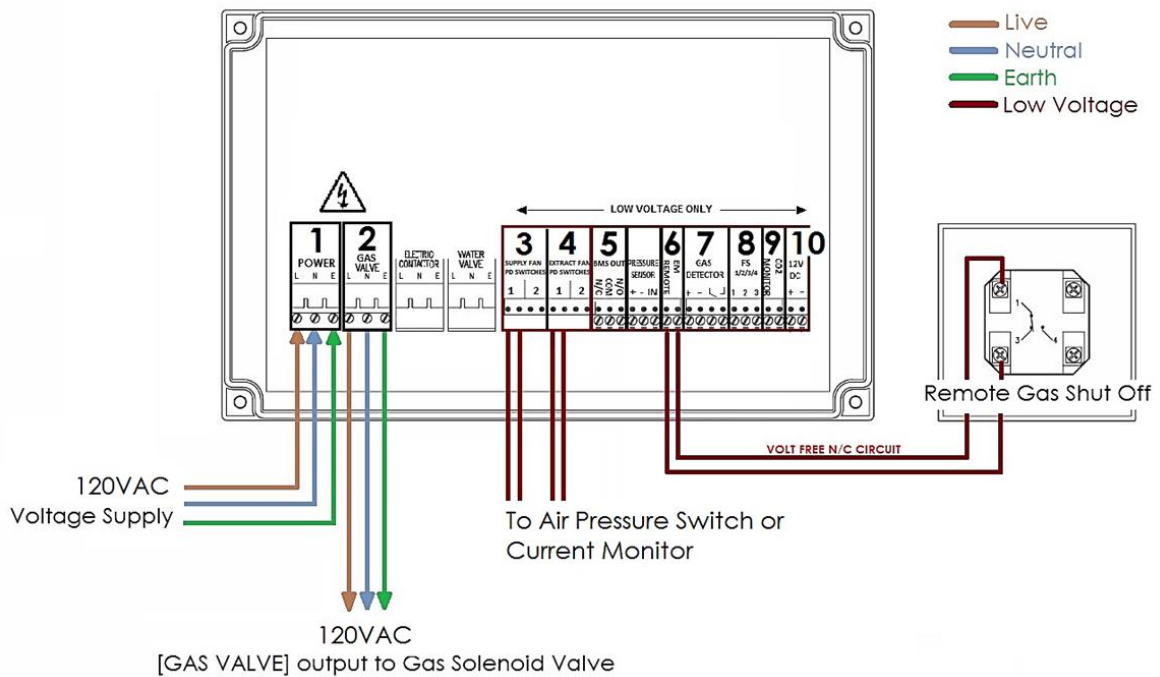

1. LINE VOLTAGE: Mains Input 110-120VAC. Single phase
2. VALVE OUT: Gas Solenoid Valve Power Output, 110-120VAC. Max 3A
3. SUPPLY FAN 1 and 2 external pressure differential switch or current switch. **VOLT FREE INPUT**
4. EXTRACT FAN 1 and 2 external pressure differential switch or current switch. **VOLT FREE INPUT**
5. BMS OUT contacts. Normally Closed, Common and Normally Open.
6. EM REMOTE: Remote EM Stop buttons and Fire Alarm input wired in series (purchased separately). **VOLT FREE INPUT**
7. GAS DETECTOR: power supply and **VOLT FREE INPUT** (purchased separately).
8. FS1/2/3/4: Fan Switch output (purchased separately).  
For wiring instruction see Fan Switch user manual.
9. CO2 MONITOR: (purchased separately). **VOLT FREE INPUT**
10. 12VDC: Permanent 12VDC output (Normally used to power a PM2 Current Monitor). **50A Max.**



## 6 Manufacturer's Warranty

### 3 Year Limited Warranty

**Warranty coverage:** The manufacturer warrants to the original consumer purchaser, that this product will be free of defects in material and workmanship for a period of three (3) years from date of purchase. The manufacturer's liability hereunder is limited to replacement of the product with repaired product at the discretion of the manufacture. This warranty is void if the product has been damaged by accident, unreasonable use, neglect, tampering or other causes not arising from defects in material or workmanship. This warranty extends to the original consumer purchaser of the product only.

**Warranty disclaimers:** Any implied warranties arising out of this sale, including but not limited to the implied warranties of description, merchantability and intended operational purpose, are limited in duration to the above warranty period. In no event shall the manufacturer be liable for loss of use of this product or for any indirect, special, incidental or consequential damages, or costs, or expenses incurred by the consumer or any other user of this product, whether due to a breach of contract, negligence, strict liability in tort or otherwise. The manufacturer shall have no liability for any personal injury, property damage or any special, incidental, contingent or consequential damage of any kind resulting from gas leakage, fire or explosion. This warranty does not affect your statutory rights.

**Warranty Performance:** During the above warranty period, your product will be replaced with a comparable product if the defective product is returned together with proof of purchase date. The replacement product will be in warranty for the remainder of the original warranty period or for six months – whichever is the greatest.

#### CONTACT US:

##### AGS Head Office

Tel: (727) 608-4375

Fax: (727) 538-4237

info@americangassafety.com



American Gas Safety is the owner of this document and reserves all rights of modification without prior notice.