

Series SOLVLV212 Solenoid Valve



Applications:

- Pumps. Laundry equipment.
- Irrigation. Compressors. Pollution Controls.
- Heating with medium or high pressure steam.
- Autoclaves. Industrial laundry equipment.
- Spraying. Irrigation.
- Air dryers. Water treatment.

Main Characteristics.

- Normally closed or normally open.
- Servo-operated action.
- 3/4" to 3" BSP or NPT threaded connections.
- Body: Forged brass or stainless steel.
- Core tube SS. 304 and 316.
- Plunger and fixed core: SS. 430 F.
- Shading coil: copper, silver or aluminium
- Shape A DIN 43650 connection encapsulated coils.
- IP 65 and NEMA4 Protection.

Options:

- Energized coil indicator light.
- Explosion and/or weather proof coils and housings
- Manual operator on pilot orifice.
- Manual operator on main passage.

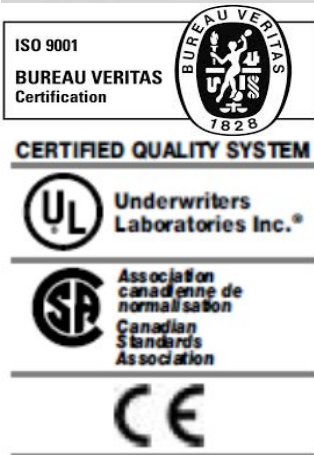

Operating pressure differential

***Advise:** when using direct current (DC), a 25% reduction on the maximum operating pressure differential is expected

Type	Minimum				Maximum steam		Maximum other fluids			
	Others seats		Buna "N" seat		PTFE seat		PTFE seat		Other seats	
	bar	psi	bar	psi	bar	psi	bar	psi	bar	psi
NC	0.5	7.5	0.2	3	10	150	17 *	255 *	15 *	225 *
NO	0.5	7.5	0.2	3	10	150	10	150	10	150

Ø Pipe ins	Ø Orifice		Flow factor		Weight		Maximum temp. and catalog N° according to seat material				
	mm	ins.	Kv	Cv	kg	Lb	Buna "N"	Neoprene	EPDM	FKM	PTFE
							80 °C / 176 °F	80 °C / 176 °F	145 °C / 293 °F	150 °C / 302 °F	180 °C / 356 °F
2.1/2"	76	3.00	66	77	19	42					

Gas Safety Systems

American Gas Safety, LLC. 4500 140th Ave N. Suite 101. Clearwater, FL 33672 T.(727) 608-4375 F.(727) 538-4237 www.americangassafety.com

Utility Control

General dimensions 1342

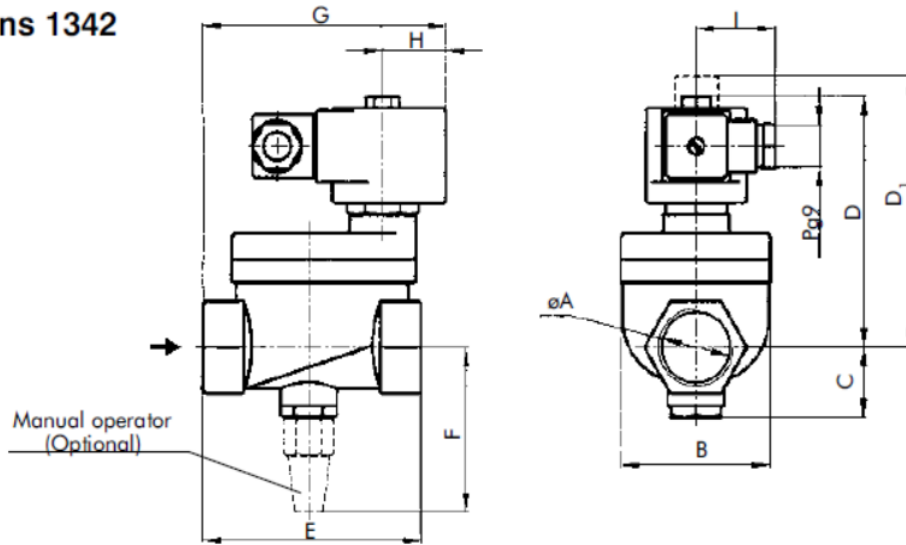

øA	B	C	D	D ₁	E	F	G	H	I
R 3/4"	52	26	104	114	71	68	84	27	35
R 1"	67	30	108	118	96	72	104		
R 1,1/2"	81	36	119	129	114	79	122		
R 2"	97	44	125	135	128	85	138		
R 2,1/2"-3"	163	89	214	224	224	170	-		

Measurements: mm

øA	B	C	D	D ₁	E	F	G	H	I
R 3/4"	2.05	1.02	4.09	4.49	2.80	2.68	3.31	1.06	1.38
R 1"	2.64	1.18	4.25	4.65	3.78	2.83	4.09		
R 1,1/2"	3.19	1.42	4.69	5.08	4.49	3.11	4.80		
R 2"	3.82	1.73	4.92	5.31	5.04	3.35	5.43		
R 2,1/2"-3"	6.42	3.50	8.43	8.82	8.82	6.69	-		

Measurements: ins.

Recommendations for installation.

Place a strainer upstream the valve with a porosity $\leq 100\mu$.
 Mount the valve preferably over horizontal pipeline with the coil upright. The valve input pressure must always be $>$ than the output pressure. In order to allow the normally closed or normally open valve to open, the minimum pressure indicated for each model must be respected.

Shape A DIN 43650 Connection encapsulated coils.
 IP65 and NEMA4 Protection.

Coil characteristics

Electric power supply	Coil type	Power W	VA (volt-ampere)		Maximum temperature		Available tensions
			Inrush	Holding	°C	°F	
AC 50 Hz	MF11C	11	40	22	155	311	1
	MH11C	11	40	22	180	356	1
AC 60 Hz	MF13C	13	45	27	155	311	2
	MH13C	13	45	27	180	356	2
DC	MH19C	19	19	19	180	356	3

1-(12,24,110,220,240)V 2-(12,24,110,120,220,240)V 3-(12,24,110,220)V