Gas Solenoid Valves

Application

AGS solenoid gas valves control the flow of natural and LP (liquefied petroleum) gases and are suitable for use on furnaces, ovens, atmospheric burners, commercial water heaters, roof-top make-up air units, power burners and commercial/industrial boilers.

Most commonly they are used with our range of utility controllers and gas detection systems.



Key Features

- Normally closed valves offer safety shut off with fast-open, fast-close operation.
- Normally open valves function as vent valves for double block and bleed gas valve trains with fast-close, fast-open operation.
- Positive close-off prevents gas from entering the burner when primary safety control turns burner off.
- Rugged design and construction.
- Valves available in sizes from 3/8" to 3"



AGS Part Numbers

Valve Size Inches NPT	AGS PART NUMBER 0-2PSI	AGS PART NUMBER 0-5PSI
3/8	MERLIN1007	MERLIN1098
1/2	MERLIN1015	MERLIN1106
3/4	MERLIN1023	MERLIN1114
1	MERLIN1031	MERLIN1122
1+1/4	MERLIN1049	MERLIN1130
1+1/2	MERLIN1056	MERLIN1148
2	MERLIN1064	MERLIN1155
2+1/2	MERLIN1072	N/A
3	MERLIN1080	N/A

Maximum Pressure

Voltage/Frequency	Maximum Pressure		Pipe size (inch)	Thread type
	psi	mbar		
110/120 Vac, 50/60 Hz	2.0	140	3/8, 1/2, 3/4, 1, 1-1/4, 1-1/2, 2, 2-1/2, 3	NPT
110/120 Vac, 50/60 Hz	5.0	350	3/8, 1/2, 3/4, 1, 1-1/4, 1-1/2, 2	NPT

Dimensions

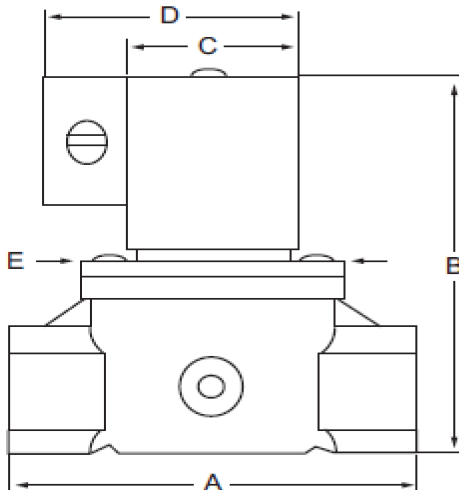

Current Draw

Normally Closed (N.C.) Pipe size (inch)	120 Vac	
	2 psi	5 psi
	3/8 and 1/2	0.160 A
3/4 and 1	0.160 A	0.200 A
1-1/4	0.340 A	0.550 A
1-1/2	0.300 A	0.550 A
2	0.525 A	0.540 A
2-1/2	0.575 A	n/a
3	0.675 A	n/a

Pipe size	A (inch)	B (inch)		C (inch)		D (inch)		E (inch) (both sides)	Weight (lbs)	
		2 psi	5 psi	2 psi	5 psi	2 psi	5 psi		2 psi	5 psi
3/8 in. NPT	2-7/8	4-7/16	4-7/16	2-3/16	2-3/16	3-3/4	3-3/4	2-3/16	2.5	2.2
1/2 in. NPT	2-7/8	4-7/16	4-7/16	2-3/16	2-3/16	3-3/4	3-3/4	2-3/16	2.5	2.2
3/4 in. NPT	3-7/16	5-1/4	5-13/16	2-3/16	2-1/2	3-3/4	4-1/16	2-3/4	4.0	4.4
1 in. NPT	3-15/16	5-1/4	6-5/16	2-3/16	2-1/2	3-3/4	4-1/16	3	4.5	4.4
1-1/4 in. NPT	5-15/16	8	8-9/16	2-1/2	3-5/16	4-1/16	4-15/16	4-3/8	12.8	10.6
1-1/2 in. NPT	5-15/16	8-3/8	8-9/16	3-3/8	3-5/16	4-15/16	4-15/16	4-3/8	12.8	10.6
2 in. NPT	6-11/16	8-3/8	9-3/16	3-3/8	3-3/4	4-15/16	5-5/16	5-3/8	14.0	13.4
2-1/2 in. NPT	9-1/2	12-3/4	—	4-9/16	—	6-1/8	—	7-7/8	28.5	—
3 in. NPT	9-1/2	12-3/4	—	4-9/16	—	6-1/8	—	7-7/8	31.0	—

INSTALLATION

When installing this product...

1. Read this instructions carefully. Failure to follow them could damage the product or cause a hazardous condition.
2. Check the rating given in the instructions and on the product to make sure the product is suitable for your application.
3. Installer must be a trained, experienced, flame safeguard control technician.
4. After installation is complete, check out product operation as provided in these instructions.



CAUTION

1. Turn off gas supply before starting installation.
2. Disconnect power supply before beginning installation to prevent electrical shock and equipment damage.
3. Do not remove seal over valve inlet or outlet until ready to connect piping.

Prepare piping and install valve (Fig. 5)

1. Use new, properly reamed pipe which is free from chips.
2. Do not thread pipe too far.
3. Apply good quality pipe dope resistant to the action of LP gas, putting a moderate amount on the male threads only. If pipe dope lodges on the valve seat, it will prevent proper closure.
4. Install valve in a horizontal pipe line, (refer to Fig. 5 for mounting position) with the gas flow matching the direction indicated by the arrow on the casting.
5. Apply a parallel jaw wrench only to the wrench flats of the valve body, next to the pipe being inserted. A wrench applied to the valve body itself or to the end farthest from the pipe being inserted may distort the casting, resulting in malfunction on the gas valve.
6. The gas flow *must* be in the same direction as the arrow on the body of the valve.

WARNING

If the flow is not in the same direction of arrow, valve may not shut off.

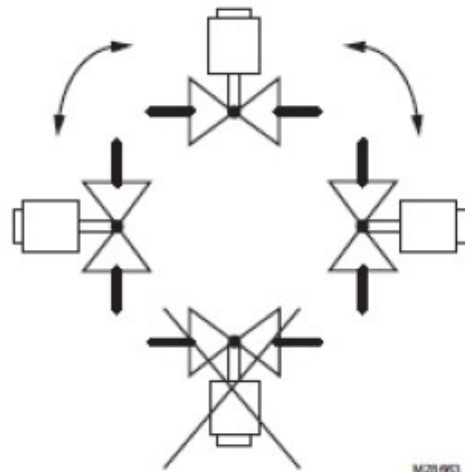

Fig. 5. Mounting position.

7. Make electrical connections as illustrated in the wiring diagrams; see Fig. 6.
8. Turn on main gas and with a soap solution, check valve installation for leaks.

WIRING

1. Disconnect power supply before making wiring connections to prevent electrical shock and equipment damage.
2. Installation and wiring must be in conformance with National Electrical Code ANSI/NFPA 70, local codes and regulations.
3. For normal installations, use moisture-resistance No. 14 wire suitable for at least 167°F (75°C) if using a Flame Safeguard Primary Control, or 194°F (90°C) if using a Flame Safeguard Programming Control.
4. For high temperature installations, use moisture resistant No. 14 wire selected for a temperature rating above the maximum operating temperature.
5. Check the power supply circuit. The voltage and frequency must match those of the valve.

