

Gas Safety Products

Merlin 1000S Gas Utility Controller

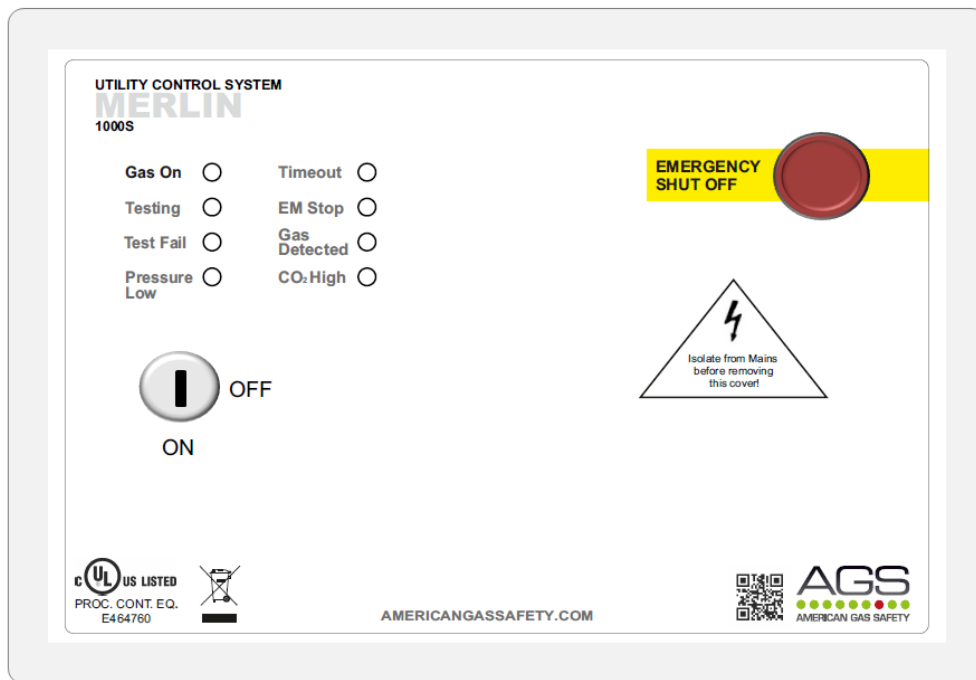

Installation, Operation and Maintenance



Table of contents

1 GENERAL INFORMATION	2
Panel Mounting.....	2
2 INSTALLATION & CONNECTION.....	3
Mains Power Supply.....	3
Gas Solenoid Valve Power Output.....	3
Building Management System Connections.....	3
Gas Pressure Transducer	4
Remote Emergency Shut Off Buttons.....	4
Gas Detectors	4
Fan Switch Output	5
CO ₂ Monitor.....	5
12v DC Output	5
Internal Buzzer	5
Panel Timeout Facility.....	5
3 OPERATION	6
How to turn the system on and off	6
Panel LED Status.....	6
Emergency Shut Off Use	7
Building Management System (BMS) Integration	7
Fire Alarm Integration.....	7
Fan Switch Integration	8
Gas Fill & Prove Time.....	8
Auto-Reset	8
1000S WIRING DIAGRAM	9

1 GENERAL INFORMATION

The Merlin 1000S is a gas shut off & gas detection utility controller.

The system comprises of a control panel and a gas pressure sensor. The Merlin 1000S can receive connections from remote emergency shut-off buttons, gas detectors and a CO₂ monitor. It can also be integrated with a BMS and fire alarm.

It is recommended that the user reads this guide before using the system. Please do NOT attempt to operate the unit until the contents of this document have been read and are thoroughly understood.

Panel Mounting

The control panel is designed for surface mounting using 4 mounting screws.

Removing the cover on the panel gives access to the circuit board. The PCB should be removed before drilling entry holes into the case.

A flush mount kit is available, comprising of a mounting bracket and decorative surround strip. Contact your supplier for more information.

2 INSTALLATION & CONNECTION

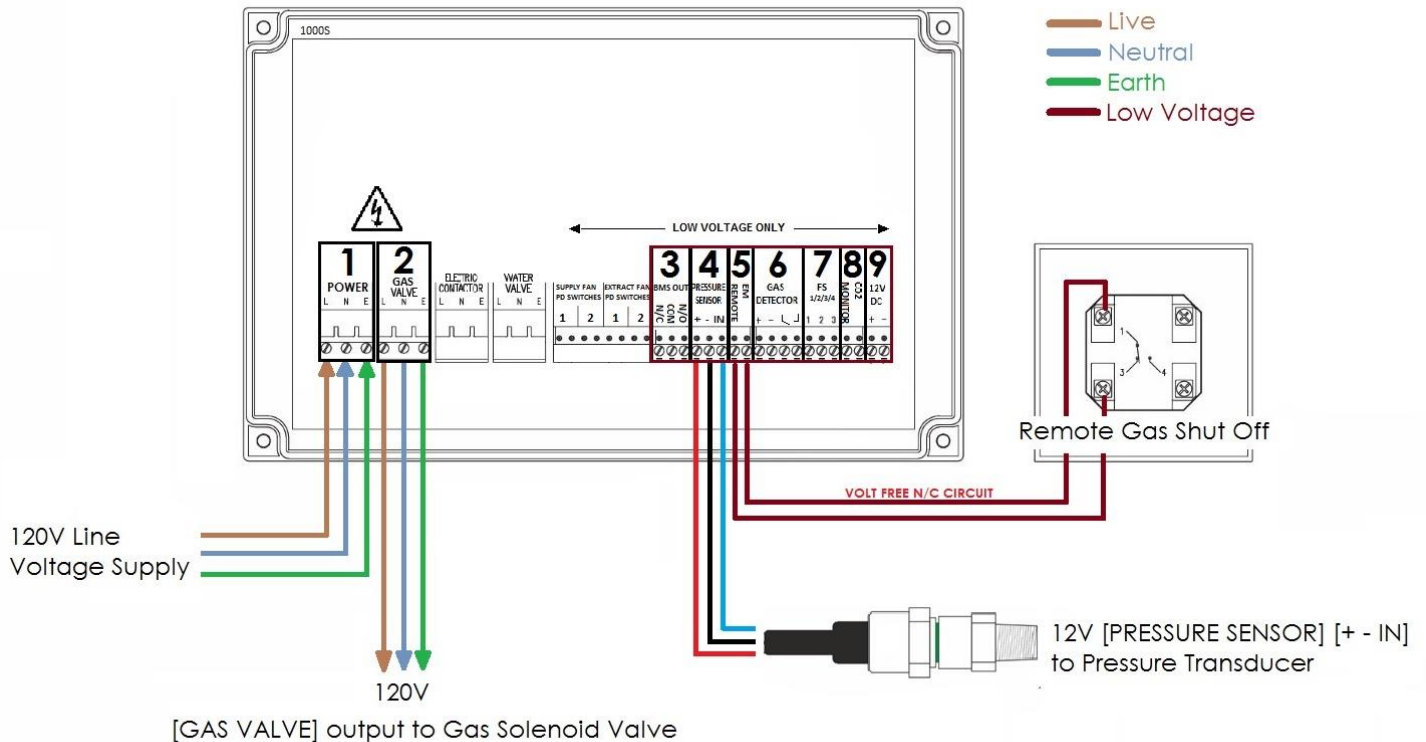

(1) [POWER L N E]

Mains Power Supply

A 110-120VAC Single Phase electrical supply should be supplied to the panel. This should be externally fused at 3 Amps using a fused or circuit breaker.

(2) [GAS VALVE L N E]

Gas Solenoid Valve Power Output

This outlet provides a 110-120VAC 3 amp signal to the solenoid valve. Please consult the solenoid valve installation instructions for further information.

(3) [BMS OUT]

Building Management System Connections

Terminal connections are available on the circuit board for connections to Building Management systems. [NC – Normally Closed] [COM - Common] [NO – Normally Open]. These are volt free dry contact connections.

This is a relay that changes state in alarm or when gas is on/off and can be used in conjunction with the 12VDC output and other external relays that affect other devices and controls such as purge fans, audible alarms etc.

(4) [PRESSURE SENSOR]

Gas Pressure Transducer

The terminals marked pressure sensor “+ - IN “.These wire to the gas pressure transducer which is screwed into the downstream port on the gas solenoid valve (see wiring below).

ENSURE THE TRANSDUCER IS CONNECTED TO THE DOWNSTREAM PORT.

Operating Pressure = 0.17psi min - 1.45psi max

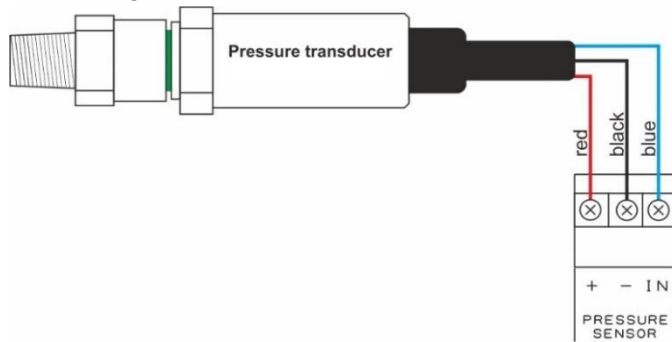
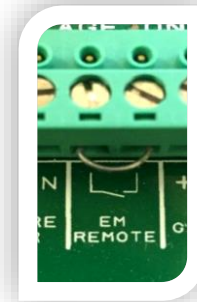

fig1

(5) [EM REMOTE]

Remote Emergency Shut Off Buttons

These connections are linked out as a factory setting. (fig1)
 Remote emergency shut-off buttons should be volt free and wired to the Merlin panel using a Plenum Security Cable. White, 18/2 (18AWG 2 Conductor), stranded, CMP or similar.



(6) [GAS DETECTOR]

Gas Detectors

These terminals are [+ -] and [~ -] and should be volt free dry contact connections. These can be wired to various Merlin gas detectors. For multiple detector wiring consult the gas detector manual (see example wiring below).

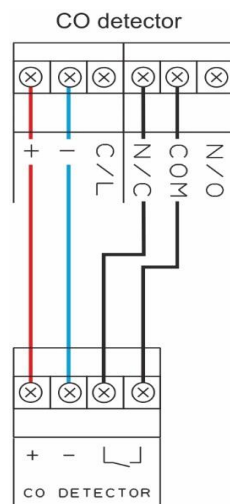

fig2



If no detector is being used leave the link in [~ -] (fig2)

(7) [FS1/2/3/4]**Fan Switch Output**

This terminal switches when the key is turned on and off. This can be linked to a fan switch (panel supplied separately) which can provide power to fans when the control panel is switched on.

(8) [CO2 MONITOR]**CO₂ Monitor**

This terminal can be wired to CO₂ monitor to shut off the system in the event of High CO₂ levels.

If no CO₂ monitor is supplied leave the terminal link in [—].

(fig3)

(9) [12VDC]**12v DC Output**

This is a permanent 12v DC output when there is power at the panel and can be used to create a relay switch with the BMS relay output. Please contact your supplier for further information.

fig3



Use a screened cable to avoid electrical interference between HIGH & LOW VOLTAGE connections

Internal Buzzer

Operates at 65dB measured 30cm from closed panel.

Panel Timeout Facility

The Merlin 1000S has a built-in Auto-shut down feature and it will turn itself off after a predefined time. Auto-shut down timeout is selectable.

There are two Dip-Switches located on the inside facia of the Merlin 1000S labelled [Time1] and [Time2]. (fig4) The gas supply will be cut off at desired time-out.

To select required timeout – configure Dip Switches as follows;

2 HOURS (FACTORY SET)

Time1 Off / Time2 Off

4 HOURS

Time1 On / Time2 Off

8 HOURS

Time1 Off / Time2 On

NO TIMEOUT

Time1 On / Time2 On (*auto-shut down disabled*)

fig4



3 OPERATION

How to turn the system on and off

- 1) Turn off all open appliances.
- 2) Turn the key switch to on position.
- 3) To turn the system off, turn the key switch to off position.

Panel LED Status

POWER

When the system is connected to mains supply, the Red LED of the AGS Logo located in the bottom right corner of the panel will illuminate.

When no power is present, this LED will not light up.

RED = OK

OFF = No power to 1000S, a loose wire/ribbon connection or the fuse may not be intact.

GAS ON

When the key switch is turned on, the Merlin 1000S will check the installation for gas leaks.

If gas proving is successful, the gas valve will open and the GAS ON LED will illuminate.

GREEN = Gas On

OFF = Gas Off

TESTING

This LED will illuminate GREEN for approximately 30 seconds when the panel is checking the integrity of the gas installation upon start up.

GREEN = proving the gas line, do NOT operate any appliances.

TEST FAIL

Under normal working conditions this LED is off.

When the panel detects a gas leak on start-up, the LED will illuminate and the gas valve will remain closed.

OFF = OK

AMBER = Gas proving failed

PRESSURE LOW

Under normal working conditions the LED is off.

The LED will illuminate when the pressure of gas supply drops below 0.17psi for 10 seconds and the gas valve will close.

OFF = OK

AMBER = Gas supply pressure low.

TIMEOUT

Under normal working conditions this LED is off. This LED will illuminate upon auto-shut down

OFF = OK

AMBER = auto-shut down

EM STOP

If an emergency shut off button (either remote or on the panel) is pressed, the LED will illuminate and the gas will be shut off. The EM Stop button must be re-set before restarting the system.

OFF = OK

AMBER = EM Stop button pressed

GAS DETECTED

Under normal working conditions this LED is off.

If the external Merlin detector connected detects gas this will illuminate and the gas valve will shut off.

OFF = OK

RED = Gas detected.

CO2 HIGH

Under normal working conditions this LED is off.

If the concentration of CO₂ in the air is at alarm level (relevant detector required), the LED will illuminate and the gas valve will shut off.

OFF = OK

RED = the concentration of CO₂ is at alarm level.

Emergency Shut Off Use

The Emergency shut off button is located on the front of the panel. There is also a facility for remote shut off buttons to be wired in series.

The Emergency shut off button(s) will cut off the gas supply when activated.

To reinstate the system, the Emergency shut off button(s) will need to be reset and the panel restarted.

Building Management System (BMS) Integration

The Merlin 1000S can be integrated with a BMS to make or break a circuit on gas on/gas off, (valve open or valve closed). This will tell the BMS whether or not power is being sent to the solenoid.

There is a dip-switch located on the inside facia of the Merlin 1000S labelled [BMS SELECTION]. This is factory set in the 'off' position which signals the BMS on gas on/gas off.

When switched to the 'on' position, the 1000S will only signal the BMS on a fault, i.e. CO₂ high level detected, gas detected, EM Stop pressed, etc.

**Fire Alarm Integration**

The Merlin 1000S can be integrated with a fire alarm to shut the gas supply automatically in the event of a fire. The volt free fire alarm signal can be wired in series with any remote emergency shut off buttons.

If there are no remote emergency stop buttons installed, wire this directly to the terminal marked [EM REMOTE].

Fan Switch Integration

There is the facility to connect a Fan Switch (FS1 or FS2 sold separately).

The Fan Switch provides the facility to turn the fan(s) ON when the Merlin panel is on and turn the fans OFF when the panel is switched off

There is a dip-switch located inside the fascia of the Merlin 1000S labelled [EM SELECTION].

This is factory set in the 'OFF' position which instructs the system to shut down the fan(s) and gas supply on activation of the Emergency shut off button(s).

On installation, this can be switched to the 'ON' position, this will instruct the system to leave the fans on and only shut off the gas supply on activation of an Emergency shut off button.

Note: This option is not available if a Fan Switch is not installed.



Gas Fill & Prove Time

Gas fill and prove times are adjustable. There are two dip-switches located on the inside fascia of the Merlin 1000S labelled [FILL TIME] and [PROVE TIME].

They are factory set in the OFF position.

Fill and prove time can be changed by switching the relevant dip switch as follows;

[FILL TIME]: Off – 5 seconds. On – 10 seconds

[PROVE TIME] Off – 30 seconds. On – 50 seconds

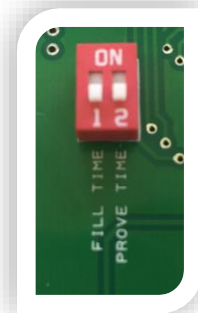

Once selected - please remove power from the fuse spur for 10 seconds.

Auto-Reset

The Merlin 1000S has a built-in auto reset feature. There is a dip-switch located on the inside fascia of the Merlin 1000S labelled [Auto Reset].

This is factory set in the 'OFF' position, this means, if you experience a power cut, the panel has to be restarted manually.

This can be switched to the 'ON' position and will instruct the system to restart automatically when power is restored following a power cut or similar situation.



1000S WIRING DIAGRAM

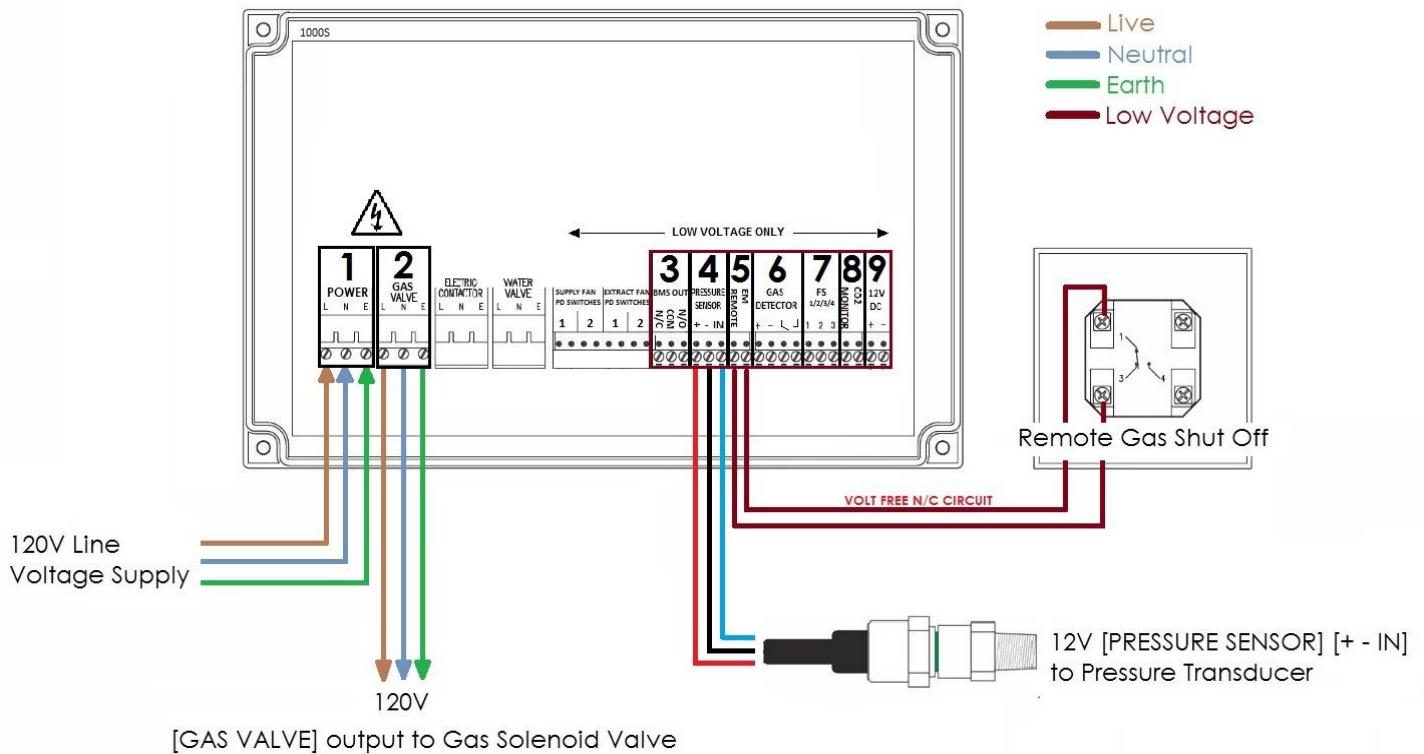

- 1) [LNE POWER] **Mains Input 110-120VAC Single Phase.**
- 2) [LNE GAS VALVE] **110-120VAC, Max 3A.**
- 3) [BMS OUT] **Max.1A @ 120VAC.**
- 4) [PRESSURE SENSOR] Gas Pressure Transducer input.
- 5) [EM REMOTE] Remote EM Stop buttons and Fire Alarm input wired in series (sold separately).
- 6) [GAS DETECTOR] Methane, CO or LPG Detector power supply (detector sold separately). See detector manual for more information
- 7) [FS1/2/3/4] Fan Switch output (sold separately).
- 8) [CO2 MONITOR] CO2 Monitor (sold separately).
- 9) [12VDC] Permanent 12VDC output when there is power at the panel. **50mA Max**

PLEASE NOTE:

MAINS AND LOW WIRING SHOULD NOT RUN IN THE SAME CONDUIT AS PER THE LOW VOLTAGE DIRECTIVE

**INFORMATION ON WASTE DISPOSAL FOR CONSUMERS OF ELECTRICAL & ELECTRONIC EQUIPMENT**

When this product has reached the end of its life it must be treated as Waste Electrical & Electronics Equipment (WEEE). Any WEEE marked products must not be mixed with general household waste, but kept separate for the treatment, recovery and recycling of the materials used. Please contact your supplier or local authority for details of recycling schemes in your area.

CONTACT US:**AGS Head Office**

Tel: (727) 608-4375

Fax: (727) 538-4237

info@americangassafety.com



American Gas Safety is the owner of this document and reserves all rights of modification without prior notice.